

Công ty TNHH MTV Thương mại Công nghệ VI GO VIỆT.

Địa chỉ: 181C, Tổ 2, Khu Phố 3, Phường Long Bình, Biên Hòa, Đồng Nai.



Điện thoại: 0251.2222.135 - Di động: 0938.010.892 - 0988.305.300

Email: vigoviet@gmail.com, MST: 3603113168

Website: <http://sungsondongnai.com> hoặc <http://vigoviet.com> hoặc <http://airbrush.com.vn>

 **Prona**[®]
SINCE 1985
SPRAY GUN
WORLD SPRAY GUN EXPERT



1998 July First Edition

2007 July The 16th Edition

2011 November The 17th Edition

2012 July The 18th Edition

2013 October The 19th Edition

2014 September The 20th Edition

2015 March The 21st Edition

2015 July The 22nd Edition

2016 August The 23rd Edition

2017 August The 24th Edition

2018 JUNE The 25th Edition

Company Profile

PRONA AIR TOOL MANUFACTURING LIMITED was established in the 1980's of TAIWAN. Prona is a company that specialized in high-end pneumatic tools and famous for its sophisticated research and development team, advanced machinery and equipments, precise processing technique as well as rigorous quality management. Prona factory is currently located in Fo Shan, Guang Dong with 67890m² of total area and is a sole foreign-invested company.

Prona never prides itself on present achievement, but always keep improving on the current products and technique and continue to develop new products. Our policy is to keep on improving and satisfying our customer's demand to achieve to becoming an internal brand and operating permanently brand and operating permanently, entering in the line of international brand, and operating permanently.

After 30 years of continuous endeavor, our company have created a reputable brand "Prona" which has signature products such as spray gun, pressure tank and double-layers pump. With various patented technologies, Prona products sells to worldwide and is highly praised.

Prona will continue its high standards in human resources and equipments in order to produce high-quality products to bring benefits worldwide.



Content Inde

01	▶ Company profile	
02	▶ Content Inde	
03	▶ Product code illustration	
04	▶ New product display	
05-06	▶ Low-pressure environment protection automatic spray gun	RAL-103 RAL-203 RAL-200 RA-430 RA-4300 RAL-103
07-10	▶ Universal automatic spray gun	RA-100R RA-101 RA-200 RA-103 RA-203 RA-101RC RA-88 RA-210 RA-130 RA-230
11	▶ Simplified middle/low-pressure automatic spray gun	RA-60 RA-80 RAL-60 RAL-80
12	▶ High-capacity middle/low-pressure automatic spray gun	RARL-101 RARL-200 RAR-101 RAR-200
13-14	▶ High-capacity low-pressure environment protection automatic spray gun	RAR-4300A RAR-50A RAR-1000 RAR-2000 RAR-3000
15-16	▶ High-capacity middle-pressure automatic spray gun	RAR-110 RAR-210 RAR-310 RAR-410
17	▶ Simplified high-pressure automatic spray gun	RA-C1 RA-C2 RA-S1 RA-S2 RA-MC2
18-20	▶ Circuit diagram of automatic spray gun and dimension diagram of air motor	
21-22	▶ Plane and Inner-wall extension spray gun	R103-PX RA103-PX R103-PS RA103-PS R103-L RA103-L
23-24	▶ 90° Gun head spray pattern extension spray gun	R-1218-90° R/RA/RAR-12/09/06 Set
25-26	▶ Universal extension spray gun	LR-18 LRA-18 LRAR-18 LR-18(50) LRA-18(50) LRAR-18(50)
27	▶ Directional extension spray gun	LR-10 LRA-10 LRAR-10
28	▶ Air-assisted spray gun	R-2200AC
29	▶ Mold release spray gun	MRS-F MRS-R MRS1-F MRS1-R MRS2-F MRS2-R
30	▶ Double-headed nano coating spray gun	MRS2-2R
31-34	▶ Repairment spray gun	RL-80F RL-80R RL-90F RL-90R R-53 R2 R3 R6-3L RL-50 R-51 RL-90LN RL-90R1 RL90-A
35-46	▶ Universal spray gun	R-21X R-71 R-77 R-711 R-101 R-100 R-103 R-200 R-203 R-303 R-403
47	▶ High-pressurized spray gun	R-3300
48-52	▶ Universal spray gun	R-110 R-210 R-413 R-310 R-410 R-303 R-403 R-715 R-775
53	▶ Pressurized spray gun	R-410-IP R-410-DP
54-58	▶ Low-pressure spray gun	R-4300S R-4300 R-4600 R-430 RL-403 RL-101 RL-100 RL-103 RL-200 RL-203 R-4303
59	▶ Anti-weat spray gun	R77-Z(ZP) R200-Z(ZP) RA200-Z(ZP)
60	▶ Water-in-water multicolor spray gun	SGD-R77
61	▶ High viscosity spray gun	R-871 R-2003
62	▶ Disheveled spray gun	SGD-71 SGD-RA200 SGD-RA100
63	▶ Artistic air brush and draw pump	RH-A BH-B RH-C RH-AP.....RT-32 RT-39A RT-39
64	▶ Artistic air brush and air duster gun	RH-80R RH-80F RH-90R RH-90F RG-7
65	▶ Pressure tank	RT-10A.....RT-60
66	▶ Small pressure tank bucket lid with agitator	RC-2E RT-2E RT-5M RT-5A RT-5AS RT-5E RT-5ES RB-TP
67-68	▶ Fluid agitator	RB-SA RB-CA RB-FA RB-MA RB-2A/4A/6A RB-MN RB-BA RB-LA
69-71	▶ Air-powered double diaphragm pumps	R15.....R51 BDP-12 BDP-12-S BDP-12-B
72-77	▶ Accessories	
78	▶ Air pressure-type plunger pump	R-SP1021.....R-SP2578

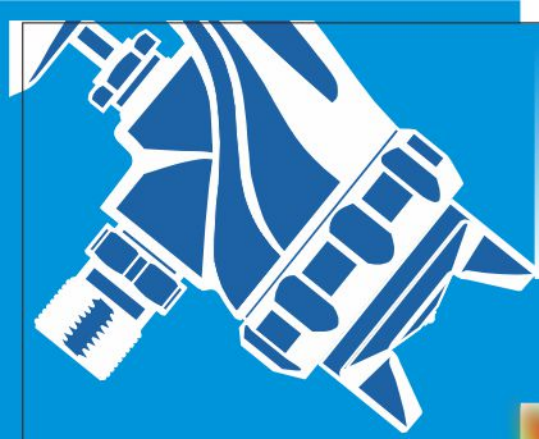

Prona Spray Gun Product Name Explanation

R-71-G15
① ② ③ ④

- ①R: Prona Spray Gun
RL: Low-Pressure Spray Gun
- ②71: Spray Gun Model
- ③G: Gravity Type of Feed
S: Suction Type of Feed
P: Pressure Type of Feed
- ④15: FLUID Nozzle Orifice
ø1.5mm

RAR-101-P08-W
① ② ③ ④ ⑤

- ①R: Prona Spray Gun
RA: Prona Automatic Spray Gun
RAL: Prona Low-Pressure Automatic Spray Gun
RAR: Prona High-Capacity Automatic Spray Gun
RARL: Prona High-Capacity Low-pressure Automatic Spray Gun
- ②101: Spray Gun Model
- ③P: Pressure Type of Model
- ④08: Nozzle size ø0.8mm
- ⑤W: Precise type

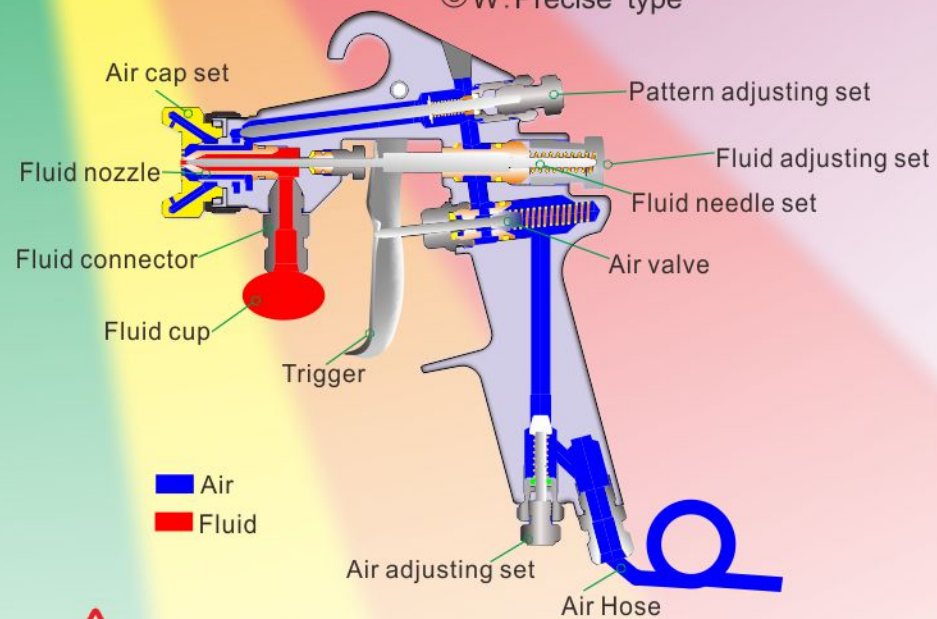

NOTE

Remove fluid knob before install or dismantle nozzle; pull the trigger to disconnect the needle and nozzle in order to eliminate the risk of the abrasion between them.

- | | | |
|--------------------------|------------------------|-----------------------------------|
| Open flames Prohibited | Wear respirator mask | Reading instruction |
| Electrostatic protection | Don't corrupt gun body | Do not excess maximum Pressure |
| Careful stab wound | Wear goggles | Do not excess maximum temperature |

Perfect result
comes from outstanding quality



Prona[®]
since 1985

R-413

R-4303



◆ For the detailed sizes of Gun-Body, please refer to page 52/55.

Modern design High quality



RAL-103-(W)

RAL-203-(W)

RAL-200

Functions and Characteristics

- ◆ Both needle and nozzle are made of stainless steel by high precision processing equipment, provide excellent abrasion and corrosion resistance.
- ◆ Fluid passage is made of stainless steel.
- ◆ Air cap undergoes precise abrasion, can provide great atomization stability. -The air pressure at the air cap is lower than 0.7 bar, can effectively reduce spattering and paint consumption.
- ◆ Suitable for applying on robot, automatic spraying machine and production line.

Model	Type of feed	Nozzle size	Air cap	Air pressure	Air consumption	Fluid output	Pattern width	Weight
		ømm (in)		kg/cm ² (Mpa)	l/min	ml/min	mm(in)	g(lbs)
RAL-100(103)(101)-P08(W)	Pressure	0.8(0.031)	E1	2.0-3.0 (0.2-0.29)	430	140	200(7.87)	465 (1.03)
RAL-100(103)(101)-P10(W)		1.0(0.039)	E1		430	150	200(7.87)	
RAL-100(103)(101)-P12(W)		1.2(0.047)	G2		530	350	270(10.62)	
RAL-200(203)-P08(W)	Pressure	0.8(0.031)	G2	2.0-3.0 (0.2-0.29)	530	400	300(10.81)	540 (1.19)
RAL-200(203)-P10(W)		1.0(0.039)	G2		500	400	300(10.81)	
RAL-200(203)-P12(W)		1.2(0.047)	G2		500	500	300(10.81)	

- ◆RAL-100(101)(103): Spray distance: 200mm(7.87in) Fluid viscosity: 20±1 second/ RV-2. Coating pressure: 0.8kg/cm². Fluid, air and CYL inlet: 1/4 PF/NPF
- ◆RAL-200(203): Spray distance: 250mm(9.84in) Fluid viscosity: 20±1 second/ RV-2. Coating pressure: 0.8kg/cm². Fluid, air and CYL inlet: 1/4 PF/NPF.
- ◆For more detailed sizes of spray gun, please refer to page 19.

Coating Precision Adjusting Device Application NO:201420622306.6



1. Comfortable knob, stepless adjustment
2. The adjustment set can be applied on other automatic spray gun
3. Can accurately show and adjust the fluid output.

Precise Type



RA-4300-(W)

RA-430-(W)

Functions and Characteristics

- ◆ The gun body of RA-4300 is made of high strength forged aluminium, no internal porosity, surface preparation for anodizing and sand blasting, wear resistance, easy to clean and maintain.
- ◆ The needle and nozzle of RA-4300 are made of stainless steel, provide excellent abrasion and corrosion resistance.
- ◆ There are two types of RA-4300: HVLP(high volume low pressure) and MP. The air passage designed with multi-holes, can steadily provide air flow, reduce spattering.
- ◆ Air cap is processed by high accuracy turn-milling technology, can steadily provide fine and even atomization. Ideal for leather, furniture and hardware industries.

Model	Type of feed	Nozzle size	Air cap	Air pressure	Air consumption	Fluid output	Pattern width	Weight
		ømm (in)		kg/cm ² (Mpa)	l/min	ml/min	mm(in)	g(lbs)
RA4300(RC)-MP-P08(W)	Pressure	0.8(0.031)	MP	2.0-2.5 (0.2-0.24)	360	360	280-400 (11.02-15.75)	550 (1.21)
RA4300(RC)-MP-P11(W)		1.1(0.043)	MP		360	385		
RA4300(RC)-MP-P12(W)		1.2(0.047)	MP		360	395		
RA4300(RC)-MP-P13(W)		1.3(0.051)	MP		360	410		
RA4300(RC)-MP-P14(W)		1.4(0.055)	MP		360	420		
RA4300(RC)-MP-P15(W)		1.5(0.059)	MP		360	430		
RA4300(RC)-MP-P18(W)		1.8(0.071)	MP		360	465		
RA4300(RC)-MP-P20(W)		2.0(0.079)	MP		360	485		
RA4300(RC)-MP-P22(W)		2.2(0.087)	MP		360	500		
RA4300(RC)-HVLP-P08(W)		Pressure	0.8(0.031)		HVLP	2.0(0.2)		
RA4300(RC)-HVLP-P11(W)	1.1(0.043)		HVLP	450	278			
RA4300(RC)-HVLP-P12(W)	1.2(0.047)		HVLP	450	285			
RA4300(RC)-HVLP-P13(W)	1.3(0.051)		HVLP	450	393			
RA4300(RC)-HVLP-P14(W)	1.4(0.055)		HVLP	450	300			
RA4300(RC)-HVLP-P15(W)	1.5(0.059)	HVLP	450	320				
RA430(RC)-HVLP-P11(W)	Pressure	0.8(0.031)	HVLP	2.0-3.0 (0.2-0.29)	430	340	330(13)	550 (1.21)
RA430(RC)-HVLP-P12(W)		1.0(0.039)	HVLP		430	345	330(13)	
RA430(RC)-HVLP-P13(W)		1.2(0.047)	HVLP		430	355	340(13.39)	
RA430(RC)-HVLP-P14(W)		1.4(0.055)	HVLP		430	365	340(13.39)	

- ◆RA-4300-MP: Spray distance: 250mm(9.84in) Fluid viscosity: 20±1 second/ RV-2. Coating pressure: 0.8kg/cm². Fluid inlet: 3/8 PF/NPF. Air and CYL inlet: 1/4 PF/NPF
- ◆RA-4300-HVLP: Spray distance: 200mm(7.87in) Fluid viscosity: 20±1 second/ RV-2. Coating pressure: 0.4-0.6kg/cm². Fluid inlet: 3/8 PF/NPF. Air and CYL inlet: 1/4 PF/NPF
- ◆RA-430-HVLP: Spray distance: 200mm(7.87in) Fluid viscosity: 20±1 second/ RV-2. Coating pressure: 0.4-0.6kg/cm². Fluid inlet: 3/8 PF/NPF. Air and CYL inlet: 1/4 PF/NPF
- ◆For more detail of the product, please refer to page 19.



RA-100R
Circle Dot
Spray Gun

RA-101(W)

RA-200

Remote Spray Gun
Application NO:201520046580.8



RA-101C
Circulatory

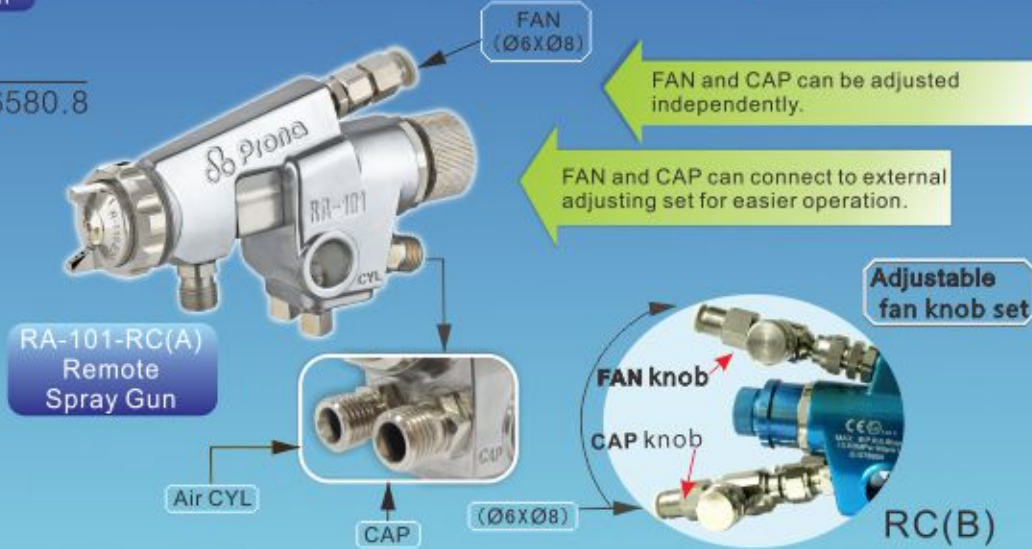

RA-101-RC(A)
Remote
Spray Gun

Adjustable
fan knob set



RA-103(W)

RA-203

Functions and Characteristics

- ◆ Air pressure can be adjusted between 2.5~3.5 bar. for less paint consumption, fine atomization, high transfer efficiency.
- ◆ Different sizes of needle and air cap are available.
- ◆ Fluid passage, needle and nozzle are made of stainless steel, suitable for spraying water based material.

Model	Type of feed	Nozzle size	Air cap	Air pressure	Air consumption	Fluid output	Pattern width	Weight	
		ømm (in)		kg/cm ² (Mpa)	l/min	ml/min	mm(in)	g(lbs)	
RA-100(101)(RC)-P08(W)	Pressure	0.8(0.031)	E2P	2.5-3.0 (0.24-0.29)	270	150	190(7.48)	475 (1.05)	
RA-100(101)(RC)-P10(W)		1.0(0.039)	E2P						220(8.66)
RA-100(101)(RC)-P10(W)		1.0(0.039)	E1						140(5.51)
RA-100(101)(RC)-P13(W)		1.3(0.051)	H2						230(9.06)
RA-100(101)(RC)-P15(W)		1.5(0.059)	H2						245(9.65)
RA-100(101)(RC)-P18(W)		1.8(0.071)	N2						230(9.06)
RA-100(101)-05R(W)		Pressure	0.5(0.020)						05R
RA-100(101)-08R(W)	0.8(0.031)		08R	60(2.36)					
RA-100(101)-10R(W)	1.0(0.039)		08R	75(2.95)					
RA-100(101)-13R(W)	1.3(0.051)		08R	90(3.54)					
RA-100(101)-15R(W)	1.5(0.059)		08R	105(4.13)					
RA-100(101)-18R(W)	1.8(0.071)		18R	95(3.74)					
RA-200(RC)-P12(W)	Pressure		1.2(0.047)	G2P	2.5-3.0 (0.24-0.29)	530	500	400(15.75)	550 (1.21)
RA-200(RC)-P15(W)		1.5(0.059)	K2	340(13.39)					
RA-200(RC)-P18(W)		1.8(0.071)	K2	340(13.39)					
RA-200(RC)-P20(W)		2.0(0.079)	R2	320(12.60)					
RA-200(RC)-P25(W)		2.5(0.098)	W2	330(13.00)					
RA-200(RC)-P20ZP(W)		2.0(0.079)	R1Z	370(14.57)					
RA-200(RC)-P25ZP(W)		2.5(0.098)	R1Z	370(14.57)					
RA-203-15R	Pressure	1.5(0.059)	15R	2.5-3.0 (0.24-0.29)	270	335	90(3.54)	530 (1.17)	
RA-203-18R		1.8(0.071)	15R						105(4.13)
RA-203-20R		2.0(0.079)	20R						110(4.33)
RA-203-25R		2.5(0.098)	25R						110(4.33)

◆RA-103: Spray distance: 200mm(7.87in) Fluid viscosity: 20±1 second/ RV-2. Coating pressure: 0.8kg/cm². Fluid, air and CYL inlet: 1/4 PF/NPF

◆RA-203: Spray distance: 250mm(9.84in) Fluid viscosity: 20±1 second/ RV-2. Coating pressure: 0.8kg/cm². Fluid, air and CYL inlet: 1/4 PF/NPF.

◆For more detail of the product, please refer to page 19.

Model	Type of feed	Nozzle size	Air cap	Air pressure	Air consumption	Fluid output	Pattern width	Weight	
		ømm (in)		kg/cm ² (Mpa)	l/min	ml/min	mm(in)	g(lbs)	
RA-103(RC)-P08(W)	Pressure	0.8(0.031)	E2P	2.5-3.0 (0.24-0.29)	270	150	190(7.48)	475 (1.05)	
RA-103(RC)-P10(W)		1.0(0.039)	E2P						220(8.66)
RA-103(RC)-P10(W)		1.0(0.039)	E1						140(5.51)
RA-103(RC)-P13(W)		1.3(0.051)	H2						230(9.06)
RA-103(RC)-P15(W)		1.5(0.059)	H2						245(9.65)
RA-103(RC)-P18(W)		1.8(0.071)	N2						230(9.06)
RA-203(RC)-P12(W)		Pressure	1.2(0.047)						G2P
RA-203(RC)-P15(W)	1.5(0.059)		K2	340(13.39)					
RA-203(RC)-P18(W)	1.8(0.071)		K2	340(13.39)					
RA-203(RC)-P20(W)	2.0(0.079)		R2	320(12.60)					
RA-203(RC)-P25(W)	2.5(0.098)		W2	330(13.00)					
RA-203(RC)-P20ZP(W)	2.0(0.079)		R1Z	370(14.57)					
RA-203(RC)-P25ZP(W)	2.5(0.098)		R1Z	370(14.57)					
RA-203-15R	Pressure	1.5(0.059)	15R	2.5-3.0 (0.24-0.29)	270	335	90(3.54)	530 (1.17)	
RA-203-18R		1.8(0.071)	15R						105(4.13)
RA-203-20R		2.0(0.079)	20R						110(4.33)
RA-203-25R		2.5(0.098)	25R						110(4.33)

◆RA-100: Spray distance: 200mm(7.87in) Fluid viscosity: 20±1 second/ RV-2. Coating pressure: 0.8kg/cm². Fluid, air and CYL inlet: 1/4 PF/NPF

◆RA-200: Spray distance: 250mm(9.84in) Fluid viscosity: 20±1 second/ RV-2. Coating pressure: 0.8kg/cm². Fluid, air and CYL inlet: 1/4 PF/NPF.

◆For more detail of the product, please refer to page 19.



RA-88

Precise Type



Functions and Characteristics

- ◆ Different size of nozzles and air caps are available.
- ◆ Needle and nozzle are made of heat-treated stainless steel.

Model	Type of feed	Nozzle size	Air cap	Air pressure	Air consumption	Fluid output	Pattern width	Weight
		ømm (in)		kg/cm ² (Mpa)	l/min	ml/min	mm(in)	g(lbs)
RA-88-P08(W)	Pressure	0.8(0.031)	08P	3.0-3.5 (0.29-0.34)	250	200	190(7.48)	537(1.18)
RA-88-P10(W)		1.0(0.039)	10P		300	300	240(9.45)	
RA-88-P13(W)		1.3(0.051)	13	2.5-3.0 (0.24-0.29)	200	170	170(6.69)	
RA-88-P15(W)		1.5(0.059)	15		240	205	190(7.48)	
RA-88-P18(W)		1.8(0.071)	18		250	240	210(8.27)	

◆RA-88 Spray distance: 200mm(7.87in) Fluid viscosity: 20±1 second/ RV-2. Coating pressure: 0.8kg/cm². Fluid, air and CYL inlet: 1/4 PF/NPF.

◆For more detailed sizes of gun-body, please refer to page 19.

- Air cap is processed by high accuracy turn-milling technology
- Featuring fine atomization
- Provide high transfer efficiency. Ideal for automotive industries.



RA-210-(W)

- Use high precision U packing.
- Provide excellent hear and wear resistance.
- Adjusting the tightness of the packing is not required.



- The gun body is made of high quality aluminum with single molding technology.
- Featuring high degree of concentricity, no internal porosity, provide excellent abrasion resistance.
- Undergoes anode and wiredrawing processing.

Model	Type of feed	Nozzle size	Air cap	Air pressure	Air consumption	Fluid output	Pattern width	Weight
		ømm (in)		kg/cm ² (Mpa)	l/min	ml/min	mm(in)	g(lbs)
RA-210-P12(W)	Pressure	1.2(0.047)	G2P	2.5-3.0 (0.24-0.29)	530	500	400(15.75)	700(1.54)
RA-210-P15(W)		1.5(0.059)	K2		330	270	340(13.39)	
RA-210-P18(W)		1.8(0.071)	K2		330	330	340(13.39)	
RA-210-P20(W)		2.0(0.079)	R2		360	400	320(12.60)	
RA-210-P25(W)		2.5(0.098)	W2	3.0-3.5 (0.29-0.34)	360	500	330(13.00)	
RA-210-P20ZP(W)		2.0(0.709)	R1Z		500	760	370(14.57)	
RA-210-P25ZP(W)		2.5(0.098)	R1Z		500	760	370(14.57)	

◆RA-210: Spray distance: 250mm(9.84in) Fluid viscosity: 20±1 second/ RV-2. Coating pressure: 0.8kg/cm². Fluid inlet: 3/8 PF/NPF. Air and CYL inlet: 1/4 PF/NPF.

◆For more detail of the product, please refer to page 19.



RA130-E2P Spray pattern



RA230-W2 Spray pattern



RA-130-(W)



RA-230-(W)

Functions and Characteristics

- ◆ Gun body is made of high strength forged aluminium, no internal porosity,
- ◆ Surface preparation for anodizing and sand blasting, wear resistance, easy to clean and maintain.
- ◆ The needle and nozzle of RA-4300 are made of stainless steel, provide excellent abrasion and corrosion resistance.
- ◆ Air cap is processed by high accuracy turn-milling technology, can steadily provide fine and even atomization. Ideal for leather, furnityre and hardware industries.

Model	Type of feed	Nozzle size	Air cap	Air pressure	Air consumption	Fluid output	Pattern width	Weight	
		ømm (in)		kg/cm ² (Mpa)	l/min	ml/min	mm(in)	g(lbs)	
RA-130-P08(W)	Pressure	0.8(0.031)	E2P	2.5-3.0 (0.24-0.29)	270	150	190(7.48)	518 (1.14)	
RA-130-P10(W)		1.0(0.039)	E2P		270	200	220(8.66)		
RA-130-P10(W)		1.0(0.039)	E1		90	100	140(5.51)		
RA-130-P13(W)		1.3(0.051)	H2		260	250	230(9.06)		
RA-130-P15(W)		1.5(0.059)	H2		260	270	245(9.65)		
RA-130-P18(W)		1.8(0.071)	N2		190	310	230(9.06)		
RA-230-P12(W)	Pressure	1.2(0.047)	G2P	2.5-3.0 (0.24-0.29)	530	500	400(15.75)	560 (1.23)	
RA-230-P15(W)		1.5(0.059)	K2		330	270	340(13.39)		
RA-230-P18(W)		1.8(0.071)	K2		330	330	340(13.39)		
RA-230-P20(W)		2.0(0.079)	R2		360	400	320(12.60)		
RA-230-P25(W)		2.5(0.098)	W2		360	500	330(13.00)		
RA-230-P20ZP(W)		2.0(0.079)	R1Z		3.0-3.5 (0.29-0.34)	500	760		370(14.57)
RA-230-P25ZP(W)		2.5(0.098)	R1Z			500	760		370(14.57)
RA-230-15R		Pressure	1.5(0.059)		15R	2.5-3.0 (0.24-0.29)	270		335
RA-230-18R	1.8(0.071)		15R	290	425		105(4.13)		
RA-230-20R	2.0(0.079)		20R	360	470		110(4.33)		
RA-230-25R	2.5(0.098)		25R	360	460		110(4.33)		

◆RA-130: Spray distance: 200mm(7.87in) Fluid viscosity: 20±1 second/ RV-2. Coating pressure: 0.8kg/cm². Fluid, air and CYL inlet: 1/4 PF/NPF

◆RA-230: Spray distance: 250mm(9.84in) Fluid viscosity: 20±1 second/ RV-2. Coating pressure: 0.8kg/cm². Fluid, air and CYL inlet: 1/4 PF/NPF.

◆For more detail of the product, please refer to page 19.



Simplified Middle-Pressure Automatic Spray Gun



RA-60



RA-80

Simplified Low-Pressure Automatic Spray Gun



RAL-60

HVLP Cap



RAL-80

HVLP Cap

Functions and Characteristics

- ◆ The air pressure at the air cap is lower than 0.7 bar, and the air pressure can be adjusted freely between (2.0~3.0bar). Featuring large spray pattern, fine atomization and better adhesion. Reduce spattering and paint consumption.
- ◆ Suitable for spraying furniture, hand tools, and hardware, etc.
- ◆ Different size of nozzles and air caps are available.
- ◆ Both needle and nozzle are made of stainless steel, suitable for spraying water based material.

Model	Type of feed	Nozzle size	Air cap	Air pressure	Air consumption	Fluid output	Pattern width	Weight
		ømm (in)		kg/cm ² (Mpa)	l/min	ml/min	mm(in)	g(lbs)
RA-60-P08	Pressure	0.8(0.031)	E2P	2.5-3.0 (0.24-0.29)	270	150	190(7.48)	260 (0.57)
RA-60-P10		1.0(0.039)	E2P		270	200	220(8.66)	
RA-60-P13		1.3(0.051)	H2		260	250	230(9.06)	
RA-60-P15		1.5(0.059)	H2		260	270	245(9.65)	
RA-60-P18		1.8(0.071)	N2		190	310	240(9.45)	
RA-80-P12	Pressure	1.2(0.047)	G2P	2.5-3.0 (0.24-0.29)	530	500	400(15.75)	280 (0.61)
RA-80-P15		1.5(0.059)	K2		330	270	340(13.39)	
RA-80-P18		1.8(0.071)	K2		330	330	340(13.39)	
RA-80-P20		2.0(0.079)	R2		360	400	320(12.60)	
RA-80-P25		2.5(0.098)	W2		360	500	330(13.00)	
RAL-60-P08	Pressure	0.8(0.031)	E1	2.0-3.0 (0.2-0.29)	430	140	200(7.87)	241 (0.53)
RAL-60-P10		1.0(0.039)	E1		430	140	200(7.87)	
RAL-60-P12		1.2(0.047)	G2		530	300	300(11.81)	
RAL-80-P08	Pressure	0.8(0.031)	G2	2.0-3.0 (0.2-0.29)	500	400	300(11.81)	260 (0.57)
RAL-80-P10		1.0(0.039)	G2		500	400	300(11.81)	
RAL-80-P12		1.2(0.0472)	G2		500	500	300(11.81)	
RAL-80-P30		3.0(0.118)	G2		500	800	310(12.20)	

- ◆ RA-60: Spray distance: 200mm(7.87in) Fluid viscosity: 20±1 second/ RV-2. Coating pressure: 0.8kg/cm². Fluid, air and CYL inlet: 1/8 PF/NPF
- ◆ RA-80: Spray distance: 250mm(9.84in) Fluid viscosity: 20±1 second/ RV-2. Coating pressure: 0.8kg/cm². Fluid, air and CYL inlet: 1/8 PF/NPF.
- ◆ RAL-60: Spray distance: 200mm(7.87in) Fluid viscosity: 20±1 second/ RV-2. Coating pressure: 0.8kg/cm². Fluid, air and CYL inlet: 1/8 PF/NPF
- ◆ RAL-80: Spray distance: 200mm(7.87in) Fluid viscosity: 20±1 second/ RV-2. Coating pressure: 0.8kg/cm². Fluid, air and CYL inlet: 1/8 PF/NPF
- ◆ For more detail of the product, please refer to page 19.

High-Capacity Low-pressure Environment Protection Automatic Spray Gun



HVLP Cap

RARL-101



HVLP Cap

RARL-200



Precise Type

High-Capacity Middle-pressure Automatic Spray Gun



RAR-101-(W)



RAR-200-(W)



R-100-C21/X6



R-200-C21

Functions and Characteristics

- ◆ Air inlet, spray pattern and fluid output can be adjusted by the remote controller independently. Suitable for applying on robot or automatic spraying equipment.
- ◆ The air pressure at the air cap is lower than 0.7 bar, and the air pressure can be adjusted freely between 2.0~3.0bar . Provide better atomization and adhesion.
- ◆ Featuring large spray pattern and high transfer efficiency.
- ◆ Can effectively reduce spattering and paint consumption.
- ◆ Both needle and nozzle are made of stainless steel, suitable for spraying water based material.

Model	Type of feed	Nozzle size	Air cap	Air pressure	Air consumption	Fluid output	Pattern width	Weight
		ømm (in)		kg/cm ² (Mpa)	l/min	ml/min	mm(in)	g(lbs)
RARL-101-P08(W)	Pressure	0.8(0.031)	E1	2.0-3.0 (0.2-0.29)	430	140	200(7.87)	355 (0.78)
RARL-101-P10(W)		1.0(0.039)	E1		430	150	200(7.87)	
RARL-101-P12(W)		1.2(0.049)	G2		430	300	200(7.87)	
RARL-200-P08(W)	Pressure	0.8(0.031)	G2	2.0-3.0 (0.2-0.29)	530	400	300(11.81)	382 (0.84)
RARL-200-P10(W)		1.0(0.039)	G2		500	400	300(11.81)	
RARL-200-P12(W)		1.2(0.047)	G2		500	500	300(11.81)	
RAR-101-P08(W)	Pressure	0.8(0.031)	E2P	2.5-3.0 (0.24-0.29)	270	150	190(7.48)	365 (0.80)
RAR-101-P08(W)		0.8(0.031)	C21		250	150	80(3.15)	
RAR-101-P08(W)		0.8(0.031)	X6		250	150	90(3.54)	
RAR-101-P10(W)		1.0(0.039)	E2P		270	200	220(8.66)	
RAR-101-P10(W)		1.0(0.039)	E2		145	180	200(7.87)	
RAR-101-P10(W)		1.0(0.039)	C21		250	200	100(3.94)	
RAR-101-P10(W)		1.0(0.039)	X6		250	200	110(4.33)	
RAR-101-P13(W)		1.3(0.051)	H2		260	250	230(9.06)	
RAR-101-P15(W)		1.5(0.059)	H2		260	270	245(9.65)	
RAR-101-P18(W)		1.8(0.071)	N2		190	310	240(9.45)	
RAR-200-P08(W)	Pressure	0.8(0.031)	C21	2.5-3.0 (0.24-0.29)	380	300	110(4.33)	392 (0.86)
RAR-200-P10(W)		1.0(0.039)	C21		380	350	130(5.12)	
RAR-200-P12(W)		1.2(0.047)	G2P		530	500	400(15.75)	
RAR-200-P15(W)		1.5(0.059)	K2		330	270	340(13.39)	
RAR-200-P18(W)		1.8(0.071)	K2		330	330	340(13.39)	
RAR-200-P20(W)	2.0(0.079)	R2	360	400	320(12.60)			
RAR-200-P25(W)	2.5(0.098)	W2	360	500	330(13.00)			

- ◆ RARL-101: Spray distance: 200mm(7.87in) Fluid viscosity: 20±1 second/ RV-2. Coating pressure: 0.8kg/cm². Fluid, air and CYL inlet: 1/8 PF/NPF
- ◆ RARL-200: Spray distance: 200mm(7.87in) Fluid viscosity: 20±1 second/ RV-2. Coating pressure: 0.8kg/cm². Fluid, air and CYL inlet: 1/8 PF/NPF
- ◆ RAR-101: Spray distance: 200mm(7.87in) Fluid viscosity: 20±1 second/ RV-2. Coating pressure: 0.8kg/cm². Fluid, air and CYL inlet: 1/8 PF/NPF
- ◆ RAR-200: Spray distance: 250mm(9.84in) Fluid viscosity: 20±1 second/ RV-2. Coating pressure: 0.8kg/cm². Fluid, air and CYL inlet: 1/8 PF/NPF.
- ◆ For more detail of the product, please refer to page 18.



Automatic Spray Gun

Appearance Application NO:ZL 201730400280.X
Utility model Application NO:201820716012.8



RAR-4300A(S)-W

RAR50A-F
Spray pattern



RAR-50A-F(W)

RAR-50-R1(W)

Functions and Characteristics

- ◆Adoption the double-adjustment atomization design, the two adjustment set on gun body can adjust air inlet and spray pattern precisely as needed. Provide fine atomization, less air consumption, suitable for small area automatic spraying.
- ◆The gun body is made of high quality aluminum with single molding technology. Featuring high degree of concentricity, no internal porosity, surface anodizing and sand blasting, is easy to clean and maintain.
- ◆Both needle and nozzle are made of stainless steel, provide excellent abrasion resistance.
- ◆**RAR-4300A** The fluid pathway is made of aluminium alloy.
- ◆**RAR-4300A(S)** The fluid pathway is made of stainless steel.

Model	Type of feed	Nozzle size	Air cap	Air pressure	Air consumption	Fluid output	Pattern width	Weight
		ømm (in)		kg/cm ² (Mpa)	l/min	ml/min	mm(in)	g(lbs)
RAR-4300A(S)-P08(W)	Pressure	0.8(0.031)	MP	2.0-2.5 (0.2-0.24)	350-500	360	100-400 (3.94-15.75)	742 (1.64)
RAR-4300A(S)-P11(W)		1.1(0.043)				385		
RAR-4300A(S)-P12(W)		1.2(0.047)				395		
RAR-4300A(S)-P13(W)		1.3(0.051)				405		
RAR-4300A(S)-P14(W)		1.4(0.055)				410		
RAR-4300A(S)-P15(W)		1.5(0.059)				415		
RAR-4300A(S)-P18(W)		1.8(0.071)				450		
RAR-4300A(S)-P20(W)		2.0(0.079)				480		
RAR-4300A(S)-P22(W)		2.2(0.087)				505		
RAR-50A-F/R1-P04(W)		Pressure				0.4(0.016)		
RAR-50A-F/R1-P06(W)	0.6(0.024)		06F 06R1	F:60/R1:80	F:65/R1:50	F:50(1.97)/R1:25(0.98)		
RAR-50A-F/R1-P08(W)	0.8(0.031)		08F 08R1	F:100/R1:80	F:100/R1:70	F:60(2.36)/R1:25(0.98)		
RAR-50A-F/R1-P10(W)	1.0(0.039)		10F 10R1	F:100/R1:80	F:120/R1:95	F:60(2.36)/R1:30(1.18)		
RAR-50A-F/R1-P12(W)	1.2(0.047)		10F 10R1	F:100/R1:80	F:160/R1:125	F:80(3.15)/R1:30(1.18)		

- ◆RAR-4300A(S)-(W) :Spray Distance:200-250mm(7.87-9.84in), Fluid viscosity:20±1 seconds/RV-2. Coating pressure:0.8kg/cm². CAP/FAN:Ø8XØ10,CYL:Ø6XØ8, FLU:1/4PF/NPF.
- ◆RAR-50A/R1-F :Spray Distance:150mm(5.91in), Fluid Viscosity:20±1 seconds/RV-2. Coating pressure:0.8kg/cm². Fluid Hose Orifice, atomization Hose Orifice, Fan pattern orifice and Air Hose Orifice:Ø4XØ6mm.
- ◆For more detail of the product, please refer to page 20.



RAR-1000

RAR-2000(W)

RAR-3000(W)



Specify please flip to page 16

Functions and Characteristics

- ◆Featuring perfect atomization, high transfer efficiency, less air and paint consumption
- ◆Needle and nozzle are made of stainless steel.
- ◆Smooth fluid passage improve washability and the prevention of paint adhesion in air cap, lower maintenance cost, suitable for spraying water based material.
- ◆Dividened-body design is easy to disassembly, adjustment is not required after maintenance.
- ◆High-performance spray gun is ideal for automotive, plastic, woodworking and ceramic industries.

Model	Type of feed	Nozzle size	Air pressure	Air consumption	Fluid output	Pattern width	Weight
		ømm (in)	kg/cm ² (Mpa)	l/min	ml/min	mm(in)	g(lbs)
RAR-1000-P07	Pressure	0.7(0.028)	2.0(0.20)	280	180	180(7.07)	545(1.20)
RAR-1000-P11		1.1(0.043)			200	230(9.06)	
RAR-1000-P14		1.4(0.055)			220	260(10.24)	
RAR-1000-P17		1.7(0.067)			250	290(11.42)	
RAR-2000-P07(W)	Pressure	0.7(0.028)	2.0(0.20)	280	180	180(7.07)	611(1.35)
RAR-2000-P11(W)		1.1(0.043)			200	230(9.06)	
RAR-2000-P14(W)		1.4(0.055)			220	260(10.24)	
RAR-2000-P17(W)		1.7(0.067)			250	290(11.42)	
RAR-3000-P07(W)	Pressure	0.7(0.028)	2.0(0.20)	280	180	180(7.07)	705(1.55)
RAR-3000-P11(W)		1.1(0.043)			200	230(9.06)	
RAR-3000-P14(W)		1.4(0.055)			220	260(10.24)	
RAR-3000-P17(W)		1.7(0.067)			250	290(11.42)	

- ◆RAR-1000/2000/3000: Spray distance: 200mm(7.87in) Fluid viscosity: 20±1 second/ RV-2. Coating pressure: 0.7-1.0kg/cm². F Fluid hose, air hose, atomization hose and fan pattern size: ø4 x ø6mm.
- ◆For more detail of the product, please refer to page 18.



Automatic Spray Gun

Application NO:201420622363.4

1. Air cap is processed with single molding technology, provide fine and even atomization.
2. The gun body is made of high quality aluminum with single molding technology. Featuring high degree of concentricity, provide perfect wear resistance.
3. Can adjust accurately by using the adjusting set.
4. Apply double fluid connector and fluid recycle design.



RAR-110(W)

RAR-210(W)

Functions and Characteristics

- ◆ Air inlet, spray pattern and fluid output can be adjusted by the remote controller independently. Suitable for applying on robot or automatic spraying equipment. Recirculating holes improve the washability of nozzle.
- ◆ The air pressure can be adjusted freely between 2.0~3.0bar. Provide better atomization and adhesion.
- ◆ Featuring large spray pattern and high transfer efficiency.
- ◆ Can effectively reduce spattering and paint consumption.
- ◆ Different size of nozzles and air caps are available.
- ◆ Both needle and nozzle are made of stainless steel, suitable for spraying water based material.

Model	Type of feed	Nozzle size	Air cap	Air pressure	Air consumption	Fluid output	Pattern width	Weight			
		ømm (in)		kg/cm ² (Mpa)	l/min	ml/min	mm(in)	g(lbs)			
RAR-110-P08(W)	Pressure	0.8(0.031)	E2P	2.5-3.0 (0.24-0.29)	270	150	190(7.48)	486 (1.07)			
RAR-110-P08(W)		0.8(0.031)	C21		250	150	80(3.15)				
RAR-110-P08(W)		0.8(0.031)	X6		250	150	90(3.54)				
RAR-110-P10(W)		1.0(0.039)	E2P		270	200	220(8.66)				
RAR-110-P10(W)		1.0(0.039)	E2		145	180	200(7.87)				
RAR-110-P10(W)		1.0(0.039)	C21		250	200	100(3.94)				
RAR-110-P10(W)		1.0(0.039)	X6		250	200	110(4.33)				
RAR-110-P13(W)		1.3(0.051)	H2		260	250	230(9.06)				
RAR-110-P15(W)		1.5(0.059)	H2		260	270	245(9.65)				
RAR-110-P18(W)		1.8(0.071)	N2		190	310	240(9.45)				
RAR-210-P08(W)		Pressure	0.8(0.031)		C21	2.5-3.0 (0.24-0.29)	380		300	110(4.33)	505 (1.11)
RAR-210-P10(W)			1.0(0.039)		C21		380		350	130(5.12)	
RAR-210-P12(W)	1.2(0.047)		G2P	530	500		400(15.75)				
RAR-210-P15(W)	1.5(0.059)		K2	330	270		340(13.39)				
RAR-210-P18(W)	1.8(0.071)		K2	330	330		340(13.39)				
RAR-210-P20(W)	2.0(0.079)		R2	360	400		320(12.60)				
RAR-210-P25(W)	2.5(0.098)		W2	360	500		330(13.00)				

- ◆RAR-110: Spray distance:200mm(7.87in). Fluid Viscosity:20±1 seconds/RV-2. Coating Pressure:0.8kg/cm². Fluid,air and CYL Intake:1/8 PF/NPF.
- ◆RAR-210 :Spray distance:250mm(9.84in). Fluid Viscosity:20±1 seconds/RV-2. Coating Pressure:0.8kg/cm². Fluid,air and CYL Intake:1/8 PF/NPF.
- ◆For more detail of the product, please refer to page 18.



Automatic Spray Gun

Application NO:201420622363.4

1. Air cap is processed with single molding technology, provide fine and even atomization.
2. The gun body is made of high quality aluminum with single molding technology. Featuring high degree of concentricity, provide perfect wear resistance.
3. Can adjust accurately by using the adjusting set.
4. Apply double fluid connector and fluid recycle design.



RAR-310(W)

RAR-410(W)



FAN、CYL、CAP can control the air passage independently, apply ø4Xø6 air hose.

FLU is the fluid inlet, is made of stainless steel, apply ø4x ø6 paint hose.

Model	Type of feed	Nozzle size	Air cap	Air pressure	Air consumption	Fluid output	Pattern width	Weight			
		ømm (in)		kg/cm ² (Mpa)	l/min	ml/min	mm(in)	g(lbs)			
RAR-310-P08(W)	Pressure	0.8(0.031)	E2P	2.5-3.0 (0.24-0.29)	270	150	190(7.48)	690 (1.52)			
RAR-310-P08(W)		0.8(0.031)	C21		250	150	80(3.15)				
RAR-310-P08(W)		0.8(0.031)	X6		250	150	90(3.54)				
RAR-310-P10(W)		1.0(0.039)	E2P		270	200	220(8.66)				
RAR-310-P10(W)		1.0(0.039)	E2		145	180	200(7.87)				
RAR-310-P10(W)		1.0(0.039)	C21		250	200	100(3.94)				
RAR-310-P10(W)		1.0(0.039)	X6		250	200	110(4.33)				
RAR-310-P13(W)		1.3(0.051)	H2		260	250	230(9.06)				
RAR-310-P15(W)		1.5(0.059)	H2		260	270	245(9.65)				
RAR-310-P18(W)		1.8(0.071)	N2		190	310	240(9.45)				
RAR-410-P08(W)		Pressure	0.8(0.031)		C21	2.5-3.0 (0.24-0.29)	380		300	110(4.33)	725 (1.60)
RAR-410-P10(W)			1.0(0.039)		C21		380		350	130(5.12)	
RAR-410-P12(W)	1.2(0.047)		G2P	530	500		400(15.75)				
RAR-410-P15(W)	1.5(0.059)		K2	330	270		340(13.39)				
RAR-410-P18(W)	1.8(0.071)		K2	330	330		340(13.39)				
RAR-410-P20(W)	2.0(0.079)		R2	360	400		320(12.60)				
RAR-410-P25(W)	2.5(0.098)		W2	360	500		330(13.00)				

- ◆RAR-310: Spray distance: 200mm(7.87in) Fluid viscosity: 20±1 second/ RV-2. Coating pressure: 0.8kg/cm². Fluid, air and fan pattern hose size: ø4 x ø6mm.
- ◆RAR-410: Spray distance: 250mm(9.84in) Fluid viscosity: 20±1 second/ RV-2. Coating pressure: 0.8kg/cm². Fluid, air and fan pattern hose size: ø4 x ø6mm.
- ◆For more detail of the product, please refer to page 18.



Functions and Characteristics

- ◆ RA-C1/C2: Gun body made of copper .
- ◆ RA-S1/S2(C), RA-S1/S1(S): Gun body made of stainless steel .
- ◆ (C): Air cap made of copper .
- ◆ (S): Air cap made of stainless steel .
- ◆ RA-C1/S1: atomizing air (CAP) and piston air (CLY) are in same air path with same connector.
- ◆ RA-C2/S2: atomizing air (CAP) and piston air (CLY) are in different air path with different connector.
- ◆ Different size of nozzles and air caps are available.
- ◆ This product has small volume , is easy to operate.



(S) stainless steel cap

Model	Type of feed	Nozzle size	Spray pattern	Air pressure	Air consumption	Water output	Pattern width	Weight
		ømm (in)		kg/cm ² (Mpa)	l/min	ml/min	mm(in)	g(lbs)
RA-C1/C2	Pressure	0.5(0.020)	Sector or Round	3.0(0.29)	60	60	200(7.87)	RA-C1:280(0.62)
		1.0(0.039)			80	250	250(9.84)	RA-C2:300(0.66)
RA-S1/S2	Pressure	1.3(0.051)	Round	3.0(0.29)	100	350	350(13.78)	RA-S1:270(0.60)
		2.0(0.079)			140	400	400(15.75)	RA-S2:280(0.62)
RA-C1R/C2R	Pressure	0.5(0.020)	Round	3.0(0.29)	40	50	50(1.97)	RA-C1R:280(0.62)
		1.0(0.039)			50	100	70(2.76)	RA-C2R:300(0.66)
RA-S1R/S2R	Pressure	1.3(0.051)	Small Round or Filament	3.0(0.29)	55	140	80(3.15)	RA-S1R:270(0.60)
		2.0(0.079)			80	180	90(3.54)	RA-S2R:280(0.62)
RA-C1S/C2S	Pressure	0.5(0.020)	Small Round or Filament	3.0(0.29)	60	40	18(0.70)	RA-C1S:280(0.62)/RA-C2S:300(0.66)
RA-S1S/S2S		0.5(0.020)			60	40	18(0.70)	RA-S1S:270(0.60)/RA-S2S:280(0.62)
RA-C1L/C2L	Pressure	1.3(0.051)	Round	3.0(0.29)	170	50	100(3.94)	RA-C1L:280(0.62)/RA-C2L:300(0.66)
		2.0(0.079)			340	60	120(4.72)	RA-S1L:270(0.60)/RA-S2L:280(0.62)

◆ For models listed above, the spray distance: 200 - 300mm (7.87 - 11.81 in).

◆ For more detail of the product, please refer to page 20.

Miniature Automatic Spray Gun



RA-MC2

RA-M1

Functions and Characteristics

- ◆ Small size, easy operation.

Model	Type of feed	Nozzle size	Spray pattern	Air pressure	Air consumption	Water output	Pattern width	Weight
		ømm (in)		kg/cm ² (Mpa)	l/min	ml/min	mm(in)	g(lbs)
RA-MC2	Pressure	0.5(0.02) 1.0(0.04)	Sector	2.0(0.2)	81	100 50	70-90(2.76-3.54) 100-130(3.94-5.12)	110(0.24)
RA-M1	Pressure	1.0(0.04)	Sector	3.0(0.29)	65	100	200(8.87)	115(0.25)

◆ RA-MC-2 Spray distance: 100 - 150mm (3.93-5.90 in).

◆ For more detail of the product, please refer to page 20.

Circuit Diagram Of Automatic Spray Gun

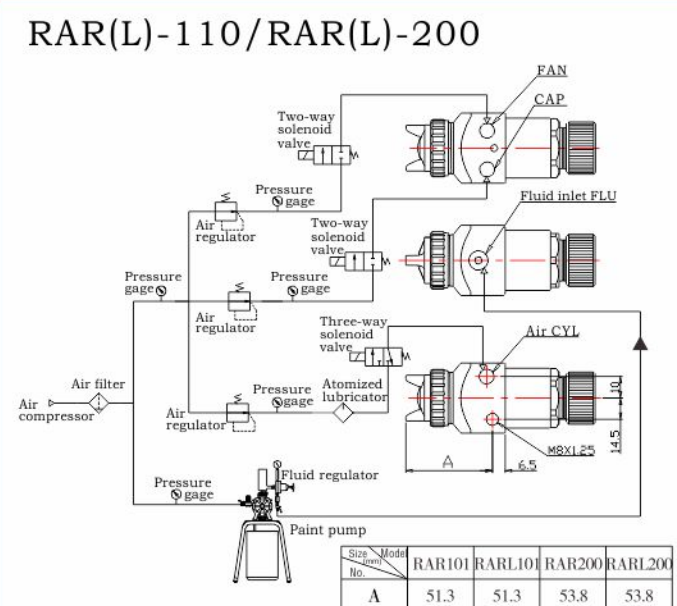
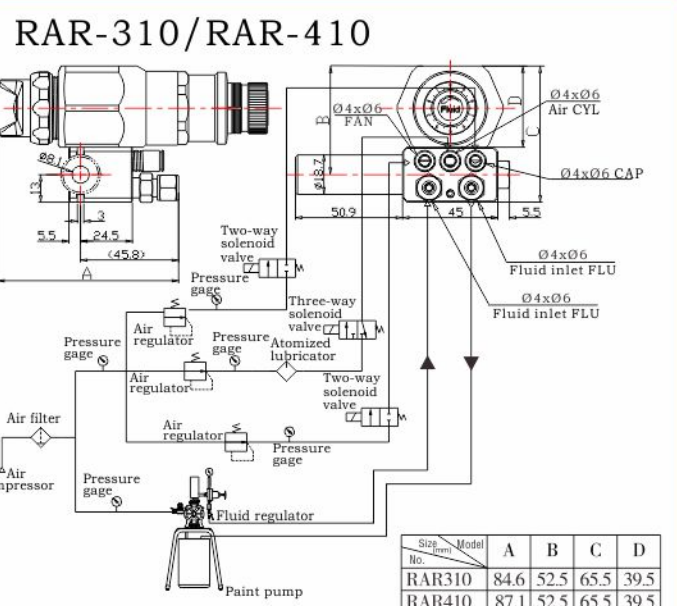
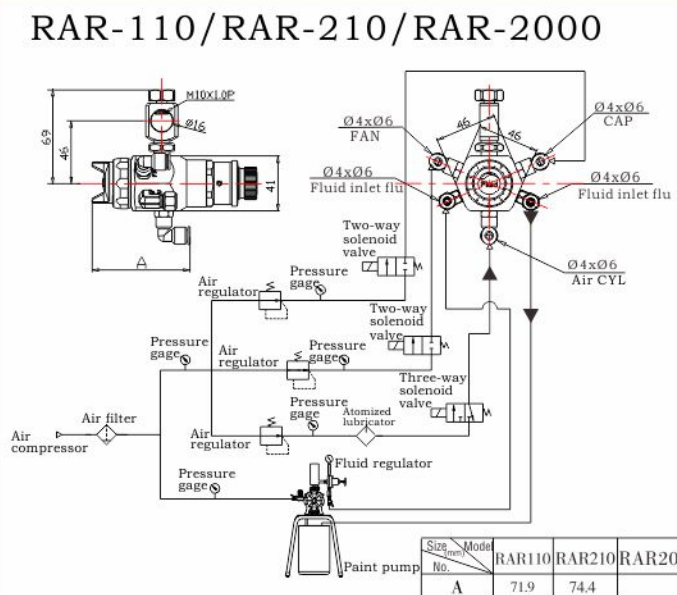
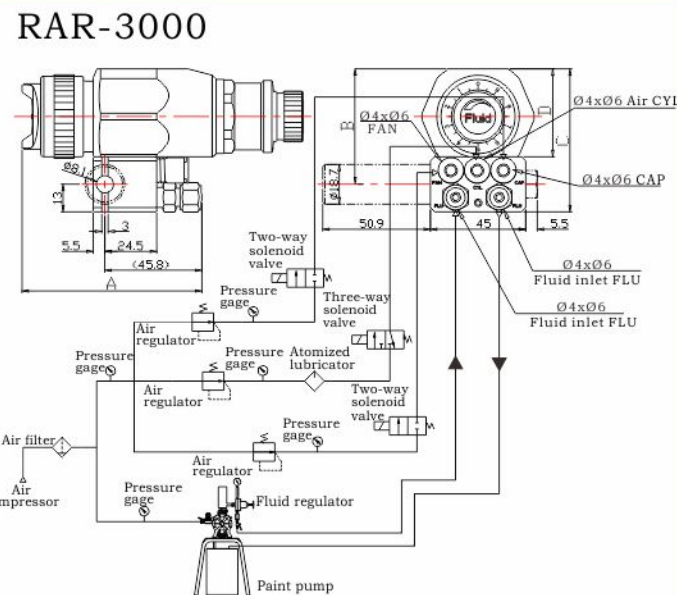
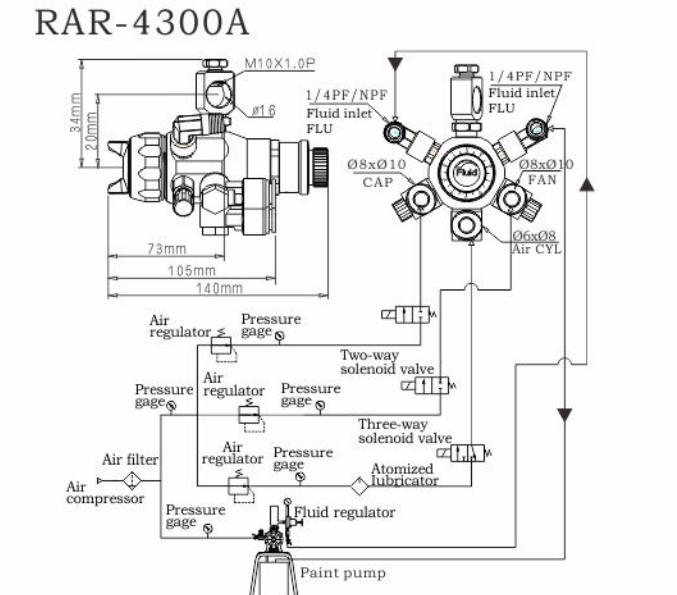
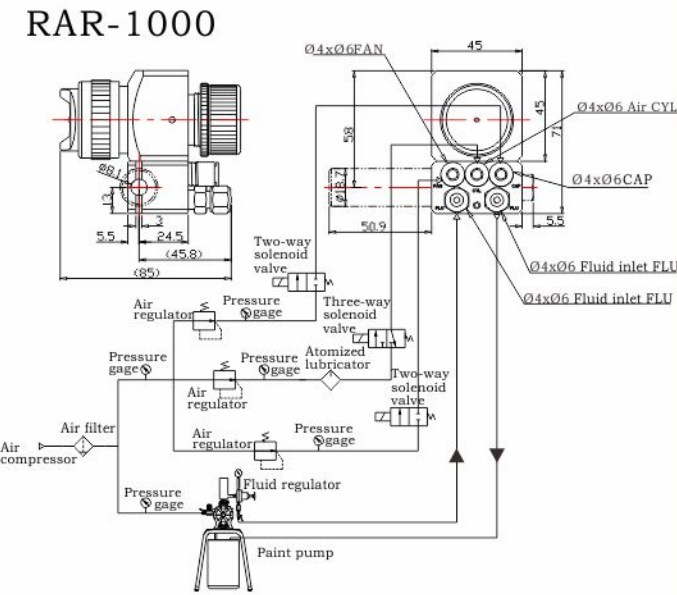

RA(L)-100/RA(L)-101/RA(L)-200/RA-88/RA-103/RA-203

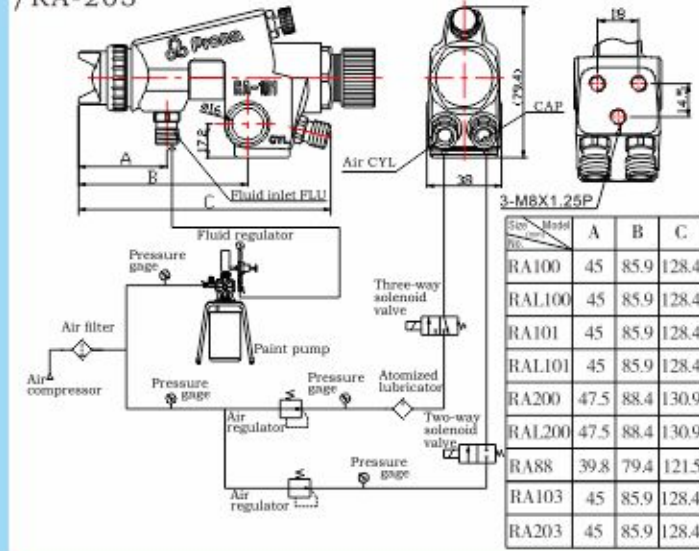

RA-101RC/RA-200RC

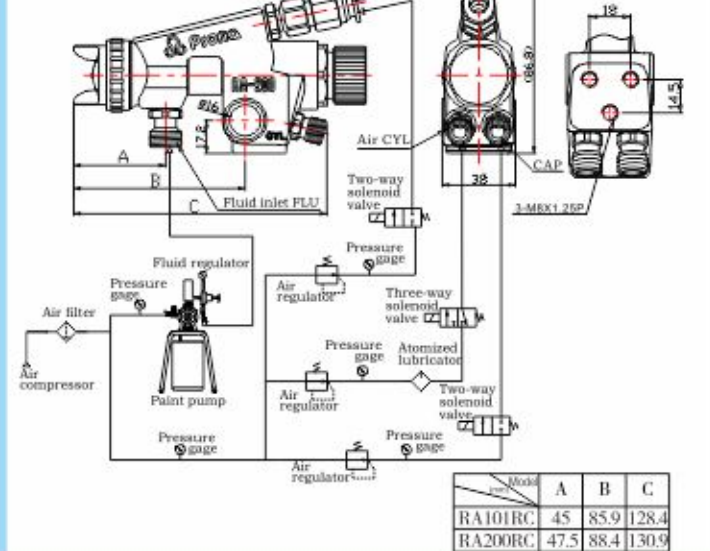

RA-C1

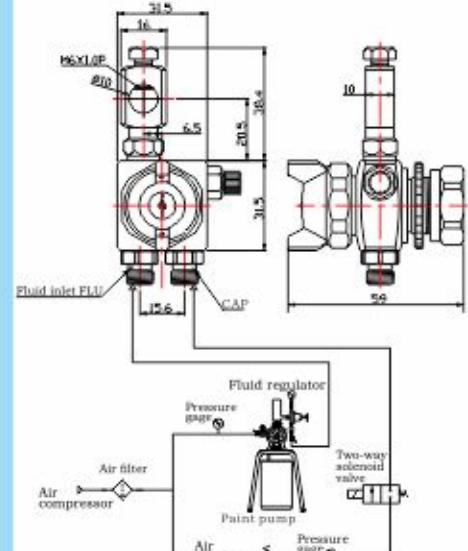

RA-C2

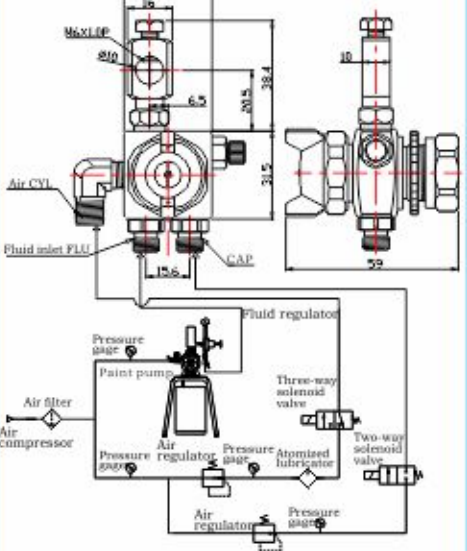

RA-S1

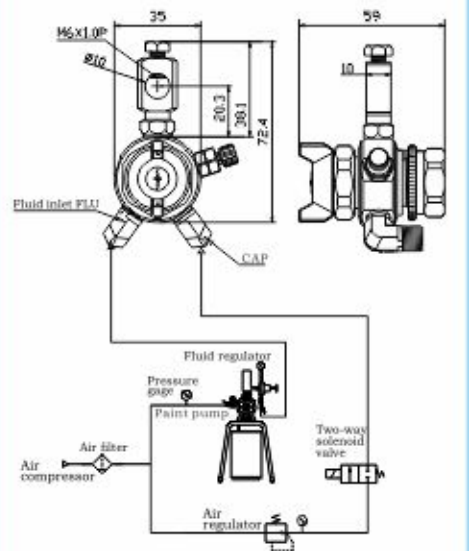

RA(L)-60/RA(L)-80

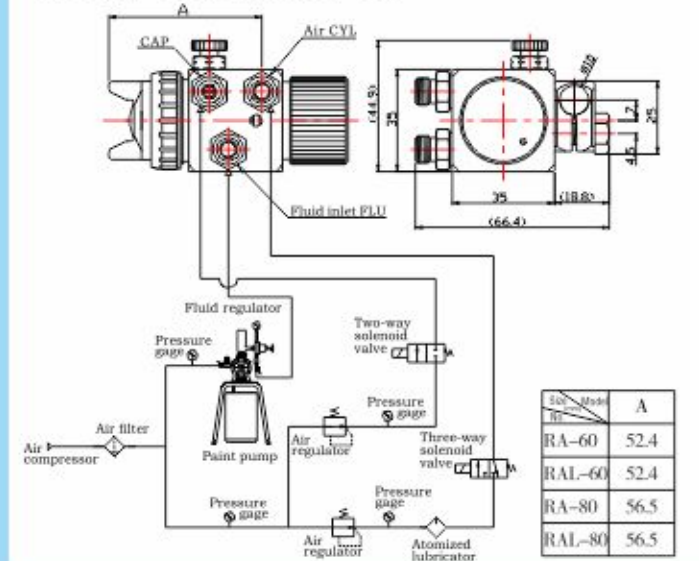

RA-210

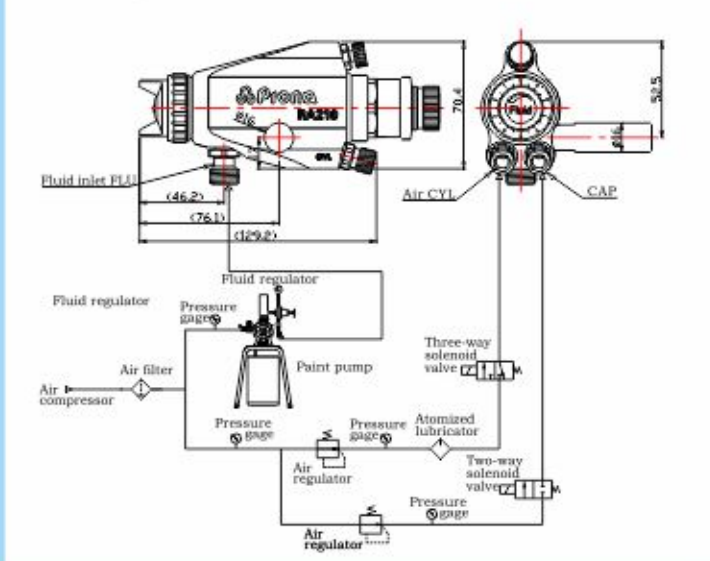

RA-S2

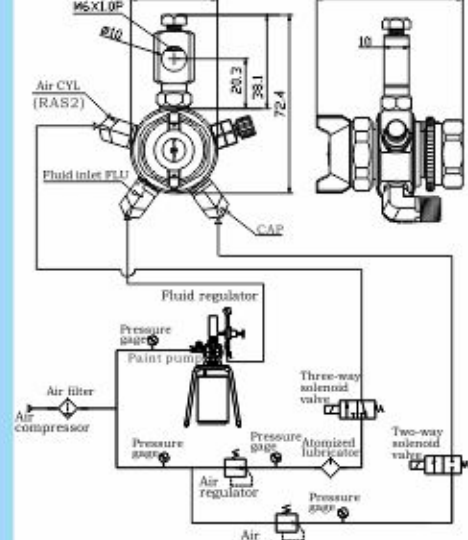

RAR-50A

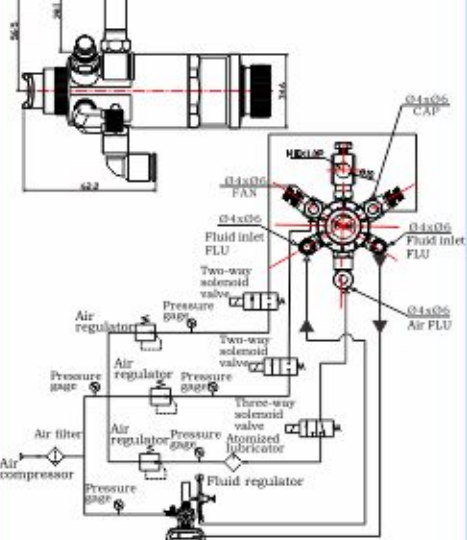

M40/M50 Dimension Diagram Of Air Motor

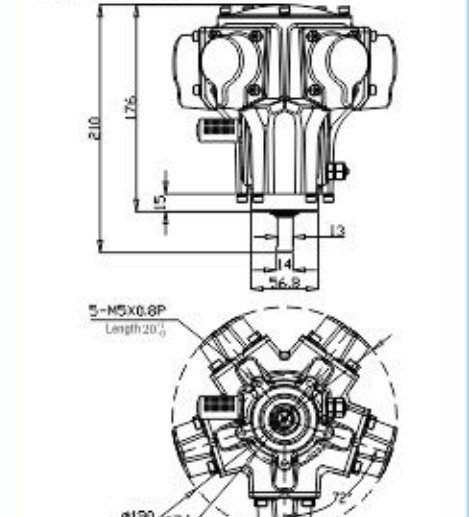

RA-4300

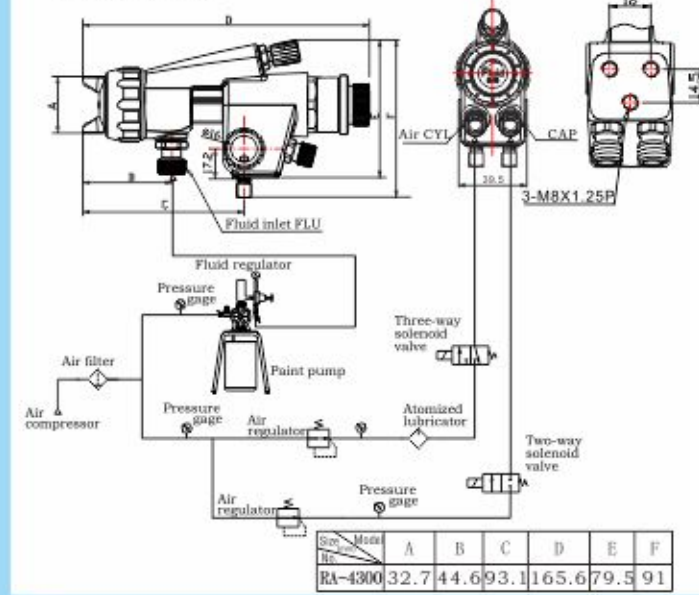

RA-130/230

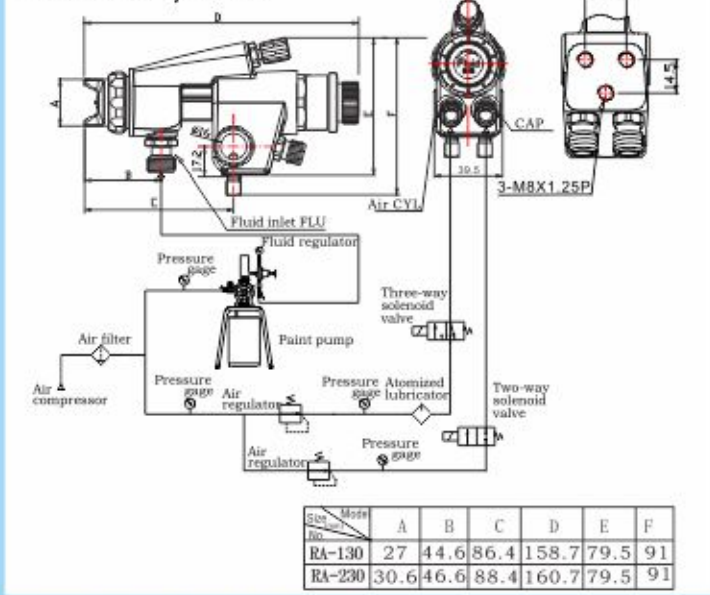

RA-MC2

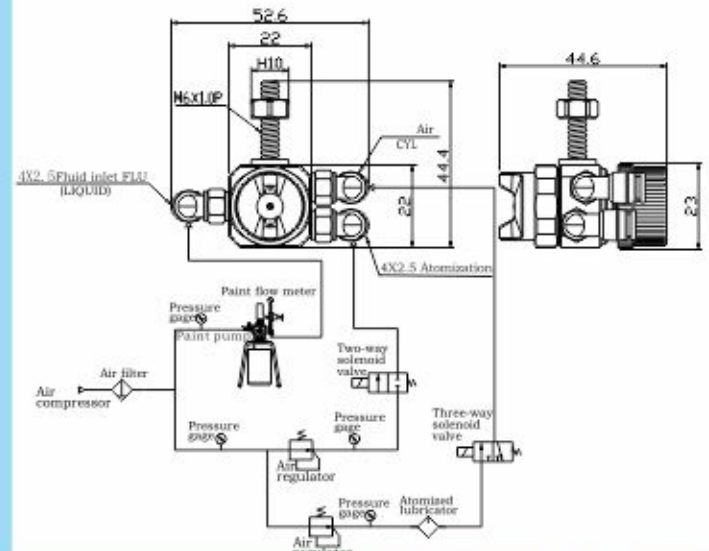

Dimension Diagram Of Air Motor

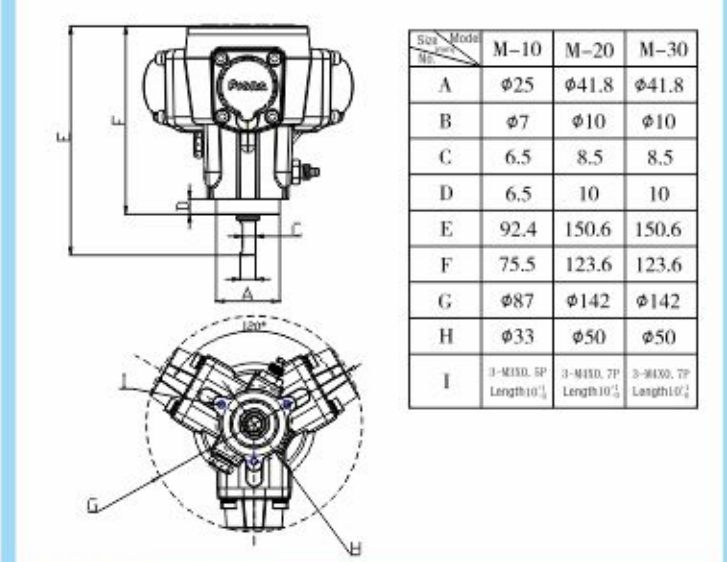



Plane and Inner-wall Extension Spray Gun

Application NO:201420622481.5

1. Air cap and needle are abrasion and corrosion resistance.
2. Rotate the pipe for adjusting the spray pattern.
3. Move the spray gun back and forth for spraying interior surfaces, easy to operate.
4. Suitable for spraying low viscosity paint.

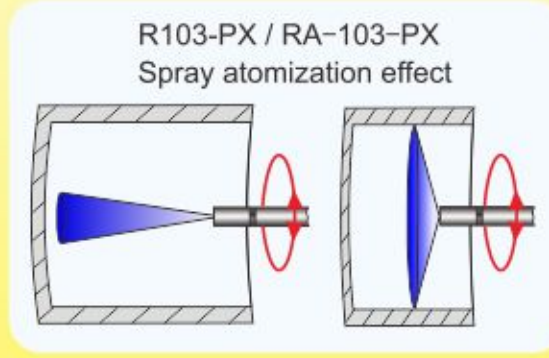

Special length can be ordered

Functions and Characteristics

- ◆ Extension spray gun is suitable for spraying long distance or other hard to reach surfaces. The nozzle is specially designed for strong adhesion paint, provide high efficiency.
- ◆ Air and fluid passage are made of stainless steel, not easy to bended or deformed, provide excellent abrasion and corrosion resistance.
- ◆ Different lengths can be selected, special specification (length) can be made according to order.
- ◆ Both needle and nozzle are made of stainless steel, suitable for water based paints.

Model	Type of feed	Nozzle size	Spray distance	Air pressure	Air consumption	Fluid output	The diameter of the out tube	Tube length	Spray width ±20	Weight
		ømm (in)	mm(in)	kg/cm ² (Mpa)	l/min	ml/min	Ømm(in)	mm(in)	mm(in)	g(lbs)
R103-12PX	Pressure	0.8(0.031)	150(5.91)	2.5-3.0 (0.25-0.3)	140	90	12(0.47)	150(5.91)	100(3.95)	564-2302 (1.24-5.07)
RA103-12PX		300(11.81)								
R103-18PX		1.0(0.051)	800(31.50)			150(5.91)				
RA103-18PX		1.3(0.051)	1000(39.37)			250(9.84)				
						130	18(0.70)	1500(59.06)	300(11.81)	
						2000(78.74)				

◆R-103-PX Fluid viscosity: 20±1 second/ RV-2. Coating pressure: 0.8kg/cm². Fluid and air inlet: 1/4 PF.NPF.
 ◆RA-103-PX Fluid viscosity: 20±1 second/ RV-2. Coating pressure: 0.8kg/cm². Fluid, air and CYL inlet: 1/4 PF.NPF.



Plane and Inner-wall Extension Spray Gun

Application NO:ZL201721126523.6

R103-PS / RA103-PS Spray atomization effect

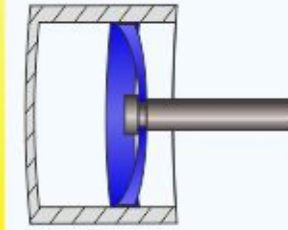

1. Suitable for low or medium viscosity paint.
2. Spray patterns are available in 360 degree, rotating pipe or spray gun is not required.
3. Ideal for spraying interior surfaces of pipe, bottle or mold.

R103-09PS/RA103-09PS suitable for low viscosity ,medium viscosity fluid .
 R103-12PS suitable for medium viscosity,high viscosity fluid.

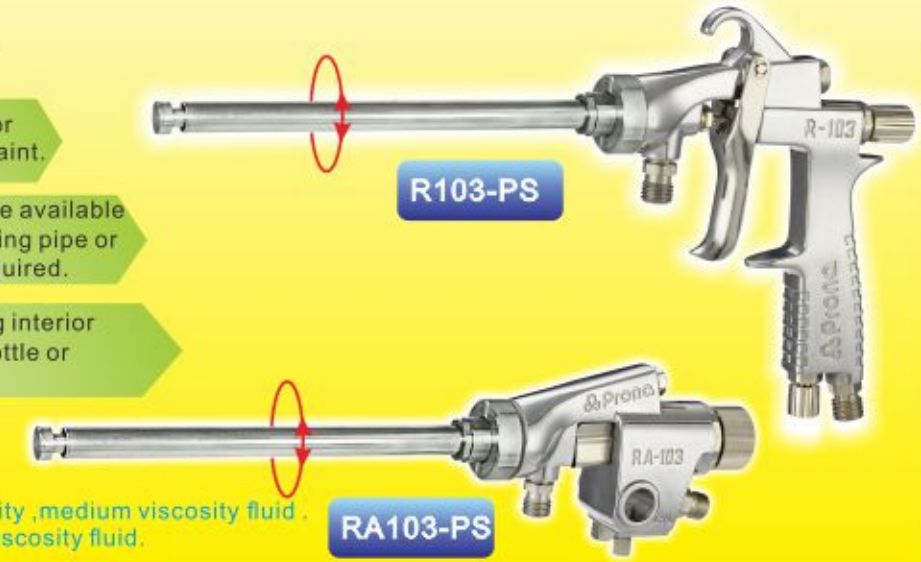

Model	Type of feed	Nozzle size	Spray distance	Air pressure	Air consumption	Fluid output	The diameter of the out tube	Tube length	Spray width ±20	Weight
		ømm (in)	mm(in)	kg/cm ² (Mpa)	l/min	ml/min	Ømm(in)	mm(in)	mm(in)	g(lbs)
R103-09PS	Pressure	0.7(0.027)	15(0.59)	2.0-2.5 (0.2-0.25)	150-200	250-300	9(0.354)	180(7.09)	65-300 (2.56-11.81)	515-850 (1.14-1.87)
RA103-09PS		300-350				250(9.84)				
R103-12PS	Pressure	1.8(0.071)	40(1.57)	2.5-3.0 (0.25-0.3)	200-230	490-520	12(0.47)	400(15.75)	100-300 (3.94-11.81)	
RA103-12PS		500(19.69)				500(19.69)				

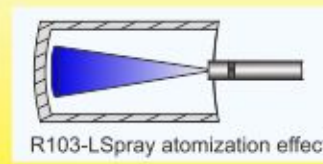

Special length can be ordered

Functions and Characteristics

- ◆ Extension spray gun is suitable for spraying long distance or other hard to reach surfaces. The nozzle is specially designed for strong adhesion paint, provide high efficiency.
- ◆ Air and fluid passage are made of stainless steel, not easy to bended or deformed, provide excellent abrasion and corrosion resistance.
- ◆ Different lengths can be selected, special specification (length) can be made according to order.
- ◆ Both needle and nozzle are made of stainless steel, suitable for water based paints.

Model	Type of feed	Nozzle size	Spray distance	Air pressure	Air consumption	Fluid output	The diameter of the out tube	Tube length	Spray width ±20	Weight
		ømm (in)	mm (in)	kg/cm ² (Mpa)	l/min	ml/min	mm(in)	mm(in)	mm(in)	g(lbs)
R103-L	Pressure	1.2(0.047)	200(7.87)	3.0-3.5 (0.29-0.34)	230	180-220	11(0.43)	150(5.91)	Maximum Inner spray width 70mm(2.76)	540-820 (1.19-1.81)
RA103-L		1.4(0.055)						500(19.69)		

◆R-103PS / R103-L Fluid viscosity: 20±1 second/ RV-2. Coating pressure: 0.5-0.8kg/cm². Fluid and air inlet: 1/4 PF.NPF.
 ◆RA-103PS / RA103-L Fluid viscosity: 20±1 second/ RV-2. Coating pressure: 0.5-0.8kg/cm². Fluid and air inlet: 1/4 PF.NPF.



90° Angle Head Fine Tube Spray Gun

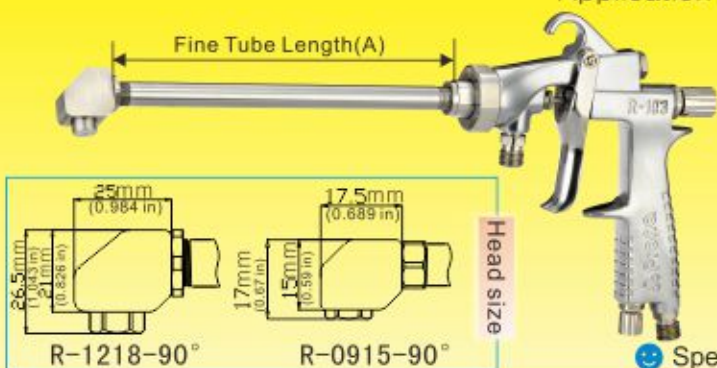

Model	Fine tube length	Nozzle size	Fluid tube orifice	Air pressure	Round±10
	mm(in)	ømm (in)	ømm (in)	kg/cm ² (Mpa)	mm(in)
R-1205-90°	50(1.97)	0.6(0.024) 1.0(0.394)	12(0.47)	2.0-3.0 (0.2-0.29)	60(2.36) 90(3.54)
R-1218-90°	180(7.09)				
R-1225-90°	250(9.84)				
R-1235-90°	350(13.77)				
R-0905-90°	50(1.97)	0.5(0.020)	9(0.35)	2.0-3.0 (0.2-0.29)	40 (1.57)
R-0915-90°	150(5.91)				
R-0925-90°	250(9.84)				
R-0935-90°	350(13.77)				

Slim Inner-wall Spray Gun

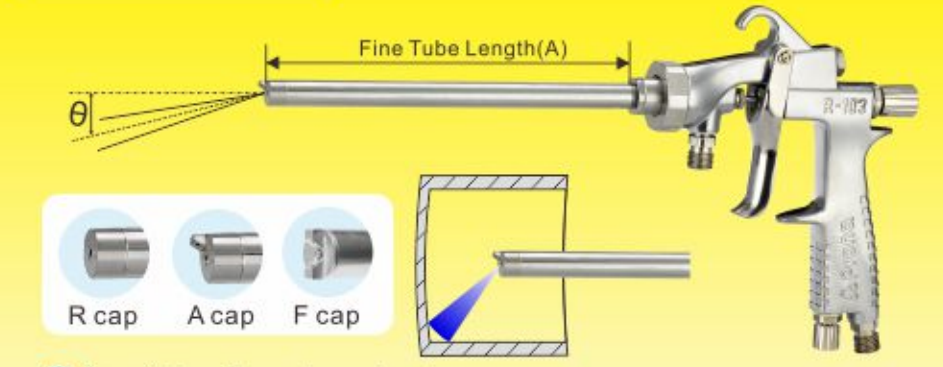

Model	Fine tube length	Nozzle size	Fluid tube orifice	Air pressure	Round±10	Angle	Pattern width±10
	mm(in)	ømm (in)	ømm (in)	kg/cm ² (Mpa)	mm(in)		mm(in)
R-1205	50(1.97)	0.6(0.024) 1.0(0.394)	12(0.47)	2.5-3.0 (0.24-0.29)	60(2.36) 90(3.54)	~19°	70(2.76) 90(3.54)
R-1218	180(7.09)						
R-1225	250(9.84)						
R-1235	350(13.77)						
R-0905	50(1.97)	0.5(0.020)	9(0.35)	2.5-3.0 (0.24-0.29)	40(1.57)	~14°	-
R-0915	150(5.91)						
R-0925	250(9.84)						
R-0935	350(13.77)						
R-0605	50(1.97)	0.5(0.020)	6(0.24)	2.5-3.0 (0.24-0.29)	25(1)	~4°	-
R-0609	90(3.54)						
R-0615	150(5.91)						
R-0625	250(9.84)						
R-0635	350(13.77)						

Functions and Characteristics

- ◆ Provide fine and even atomization.
- ◆ R cap is suitable for spraying long distance or deep internal surface.
- ◆ A cap is suitable for painting internal surfaces of pipes or bottle, also the side surface.
- ◆ Air cap and fluid tube are made of stainless steel, high hardness not easy to bended or deformed, provide excellent abrasion and corrosion resistance.
- ◆ Both needle and nozzle are made of stainless steel, suitable for water based paints.

◆ Spray distance: 150-200mm(5.90-7.87in).
Fluid viscosity:20±1 seconds/RV-2.
Coating pressure:0.8kg/cm².
Fluid and air Inlet:1/4 PF/NPF.



Slim Inner-wall Automatic Spray Gun



Model	Fine tube length	Nozzle size	Fluid tube orifice	Air pressure	Round±10	Angle	Pattern width±10
	mm(in)	ømm (in)	ømm (in)	kg/cm ² (Mpa)	mm(in)		mm(in)
RA-1205	50(1.97)	0.6(0.024) 1.0(0.394)	12(0.47)	2.5-3.0 (0.24-0.29)	60(2.36) 90(3.54)	~19°	70(2.76) 90(3.54)
RA-1218	180(7.09)						
RA-1225	250(9.84)						
RA-1235	350(13.77)						
RA-0905	50(1.97)	0.5(0.020)	9(0.35)	2.5-3.0 (0.24-0.29)	40(1.57)	~14°	-
RA-0915	150(5.91)						
RA-0925	250(9.84)						
RA-0935	350(13.77)						
RA-0605	50(1.97)	0.5(0.020)	6(0.24)	2.5-3.0 (0.24-0.29)	25(1)	~4°	-
RA-0609	90(3.54)						
RA-0615	150(5.91)						
RA-0625	250(9.84)						
RA-0635	350(13.77)						

Functions and Characteristics

- ◆ Provide fine atomization.
- ◆ R cap is suitable for spraying long distance or deep internal surface.
- ◆ A cap is suitable for painting internal surfaces of pipes or bottle, also the side surface.
- ◆ Air cap and fluid tube are made of stainless steel, high hardness not easy to bended or deformed, provide excellent abrasion and corrosion resistance.
- ◆ Both needle and nozzle are made of stainless steel, suitable for water based paints.

Note:
A cap for Angle
R cap for Round
F cap shaped for F cover
◆ Spray distance: 150-200mm(5.90-7.87in).
Fluid viscosity:20±1 seconds/RV-2.
Coating pressure:0.8kg/cm².
Fluid , Air and CYL Inlet:1/4 PF/NPF.

High-Capacity Slim Inner-wall Automatic Spray Gun

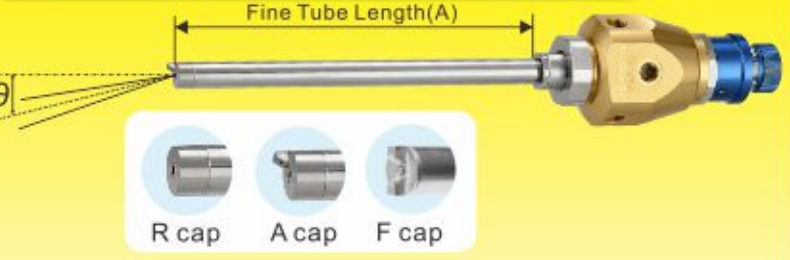

Model	Fine tube length	Nozzle size	Fluid tube orifice	Air pressure	Round±10	Angle	Pattern width±10
	mm(in)	ømm (in)	ømm (in)	kg/cm ² (Mpa)	mm(in)		mm(in)
RAR-1205	50(1.97)	0.6(0.024) 1.0(0.394)	12(0.47)	2.5-3.0 (0.24-0.29)	60(2.36) 90(3.54)	~19°	70(2.76) 90(3.54)
RAR-1218	180(7.09)						
RAR-1225	250(9.84)						
RAR-1235	350(13.77)						
RAR-0905	50(1.97)	0.5(0.020)	9(0.35)	2.5-3.0 (0.24-0.29)	40(1.57)	~14°	-
RAR-0915	150(5.91)						
RAR-0925	250(9.84)						
RAR-0935	350(13.77)						
RAR-0605	50(1.97)	0.5(0.020)	6(0.24)	2.5-3.0 (0.24-0.29)	25(1)	~4°	-
RAR-0609	90(3.54)						
RAR-0615	150(5.91)						
RAR-0625	250(9.84)						
RAR-0635	350(13.77)						

Functions and Characteristics

- ◆ Provide fine atomization.
- ◆ R cap is suitable for spraying long distance or deep internal surface.
- ◆ A cap is suitable for painting internal surfaces of pipes or bottle, also the side surface.
- ◆ Air cap and fluid tube are made of stainless steel, high hardness not easy to bended or deformed, provide excellent abrasion and corrosion resistance.
- ◆ Both needle and nozzle are made of stainless steel, suitable for water based paints.

Note:
A cap for Angle
R cap for Round
F cap shaped for F cover
◆ Spray distance: 150-200mm(5.90-7.87in).
Fluid viscosity:20±1 seconds/RV-2.
Coating pressure:0.8kg/cm².
Fluid , Air and CYL Inlet:1/8 PF/NPF.

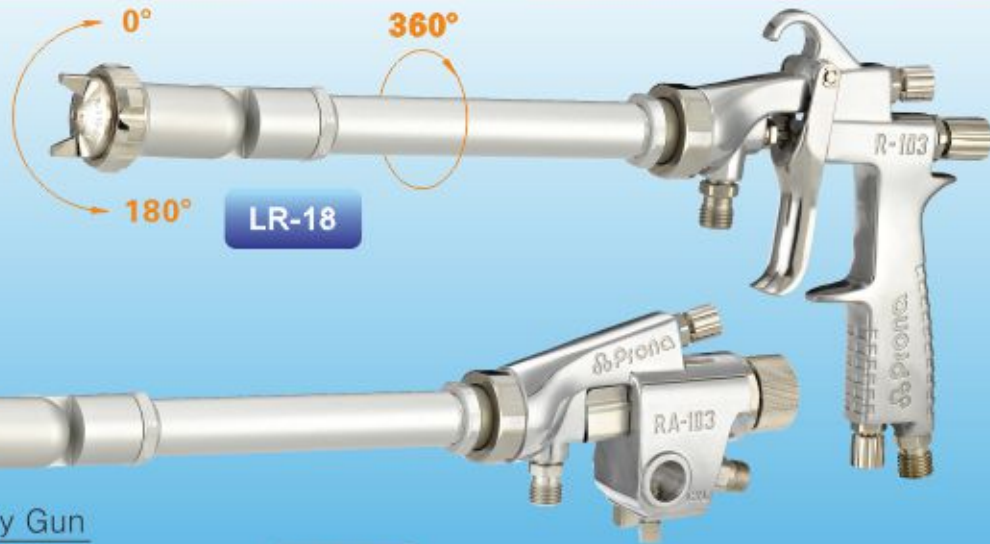

LR-18



LRA-18



LRAR-18

Universal Extension Spray Gun Application NO:201520045009.4

- 1. Gun head can rotate by 180°, and the air pipe set can rotate by 360°.
- 2. Needle, nozzle and fluid passage are made of stainless steel, provide excellent sealing performance and corrosion resistance.
- 3. Gun body is processed with a precision single-molding technology, provide fine and even atomization.

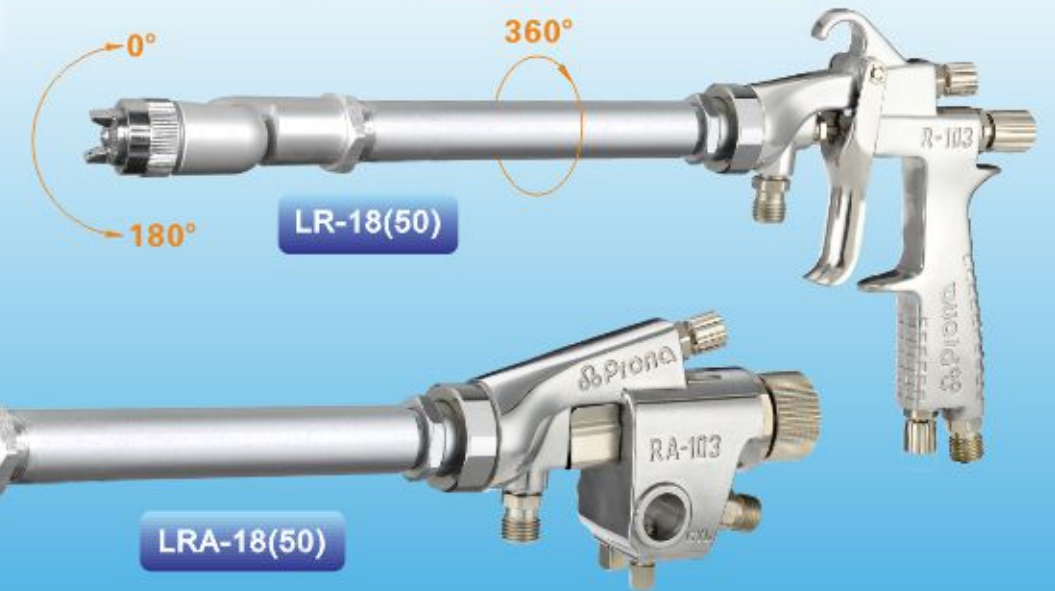
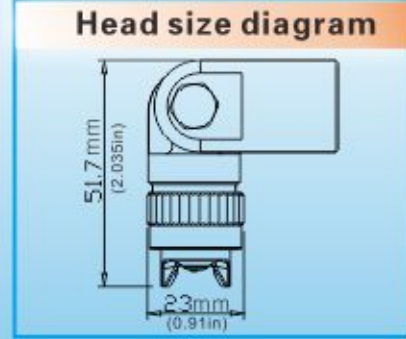

LR-18(50)

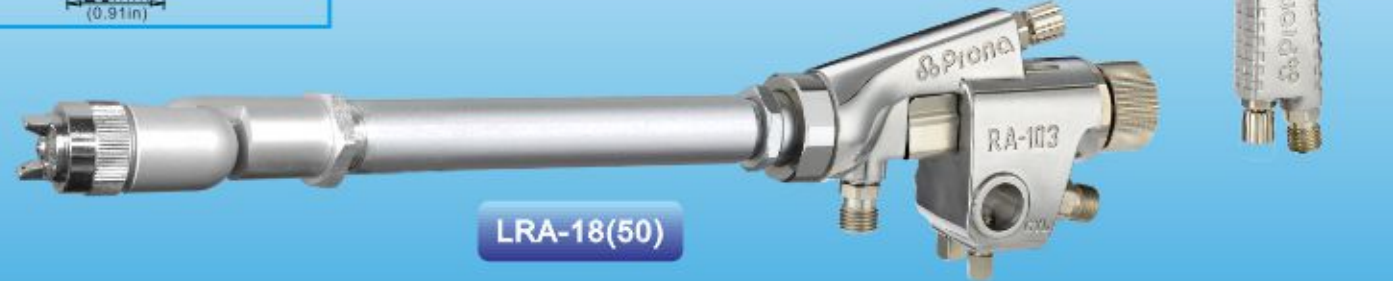

LRA-18(50)



LRAR-18(50)



LR18(Manual)/LRA18(Automatic)/LRAR18(Automatic)

Special length can be ordered
 Remark: LR18-P10-300

Model	Head angle	Nozzle size	Air cap	Air pressure	Air consumption	Fluid output	Headed length	Spray distance	Spray width ±20	Weight
		ømm (in)		kg/cm ² (Mpa)	l/min	ml/min	mm(in)	mm(in)	mm(in)	g(lbs)
LR18-P08	0° -180° (Adjustable Angle)	0.8(0.031)	E2P	2.5-3.0 (0.24-0.29)	270	150	50(1.97) 150(5.91) 300(11.81) 500(19.69) 800(31.50) 1000(39.37) 1500(59.06)	200(7.87)	190(7.48)	628-1814 (1.38-4)
LR18-P10		1.0(0.039)							220(8.66)	
LR18-P13		1.3(0.051)							210(8.27)	
LR18-P15		1.5(0.059)							240(9.45)	
LRA18-P08	0° -180° (Adjustable Angle)	0.8(0.031)	E2P	2.5-3.0 (0.24-0.29)	270	150	50(1.97) 150(5.91) 300(11.81) 500(19.69) 800(31.50) 1000(39.37) 1500(59.06)	200(7.87)	190(7.48)	772-1958 (1.7-4.32)
LRA18-P10		1.0(0.039)							220(8.66)	
LRA18-P13		1.3(0.051)							210(8.27)	
LRA18-P15		1.5(0.059)							240(9.45)	
LRAR18-P08	0° -180° (Adjustable Angle)	0.8(0.031)	E2P	2.5-3.0 (0.24-0.29)	270	150	50(1.97) 150(5.91) 300(11.81) 500(19.69) 800(31.50) 1000(39.37) 1500(59.06)	200(7.87)	190(7.48)	705-1495 (1.5-3.3)
LRAR18-P10		1.0(0.039)							220(8.66)	
LRAR18-P13		1.3(0.051)							210(8.27)	
LRAR18-P15		1.5(0.059)							240(9.45)	

◆LR-18: Fluid viscosity: 20±1 second/ RV-2. Coating pressure: 0.8kg/cm². Fluid and air inlet: 1/4 PF/NPF.
 ◆LRA-18: Fluid viscosity: 20±1 second/ RV-2. Coating pressure: 0.8kg/cm². Fluid, air and CYL inlet : 1/4 PF.NPF.
 ◆LRAR-18: Fluid viscosity: 20±1 second/ RV-2. Coating pressure: 0.8kg/cm². Fluid, air and CYL inlet: 1/8 PF.NPF.

Functions and Characteristics

- ◆Gun head can rotate by 180° and the air pipe set can rotate by 360°.
- ◆Different lengths can be selected, special specification (length) can be made according to order.
- ◆Outer tube surface receive anodization of sand blast treatment, can avoid slipping out of hands and is wear resistance.
- ◆High transfer efficiency, and provide fine and even atomization.

Special length can be ordered
 Remark: LR18(50)-P10-300

Model	Head angle	Nozzle size	Air cap	Air pressure	Air consumption	Fluid output	Headed length	Spray distance	Spray width ±20	Weight
		ømm (in)		kg/cm ² (Mpa)	l/min	ml/min	mm(in)	mm(in)	mm(in)	g(lbs)
LR18(50)-P10	0° -180° (Adjustable Angle)	1.0(0.039)	10	0.9-1.5 (0.09-0.15)	50	100	50(1.97) 150(5.91) 300(11.81) 500(19.69) 800(31.50) 1000(39.37) 1500(59.06)	150 (5.91)	100 (3.94)	571-1766 (1.26-3.89)
LRA18(50)-P10	0° -180° (Adjustable Angle)	1.0(0.039)	10	0.9-1.5 (0.09-0.15)	50	100	50(1.97) 150(5.91) 300(11.81) 500(19.69) 800(31.50) 1000(39.37) 1500(59.06)	150 (5.91)	100 (3.94)	517-1943 (1.58-4.28)
LRAR18(50)-P10	0° -180° (Adjustable Angle)	1.0(0.039)	10	0.9-1.5 (0.09-0.15)	50	100	50(1.97) 150(5.91) 300(11.81) 500(19.69) 800(31.50) 1000(39.37) 1500(59.06)	150 (5.91)	100 (3.94)	517-1943 (1.58-4.28)

◆LR-18(50): Fluid viscosity: 20±1 second/ RV-2. Coating pressure: 0.8kg/cm². Fluid and air inlet: 1/4 PF/NPF.
 ◆LRA-18(50): Fluid viscosity: 20±1 second/ RV-2. Coating pressure: 0.8kg/cm². Fluid, air and CYL inlet : 1/4 PF.NPF.
 ◆LRAR(50)-18: Fluid viscosity: 20±1 second/ RV-2. Coating pressure: 0.8kg/cm². Fluid, air and CYL inlet: 1/8 PF.NPF.



Head diagram

LR10-0°

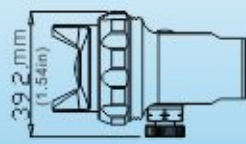

LR10-45°

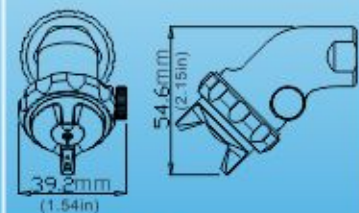

LR10-90°

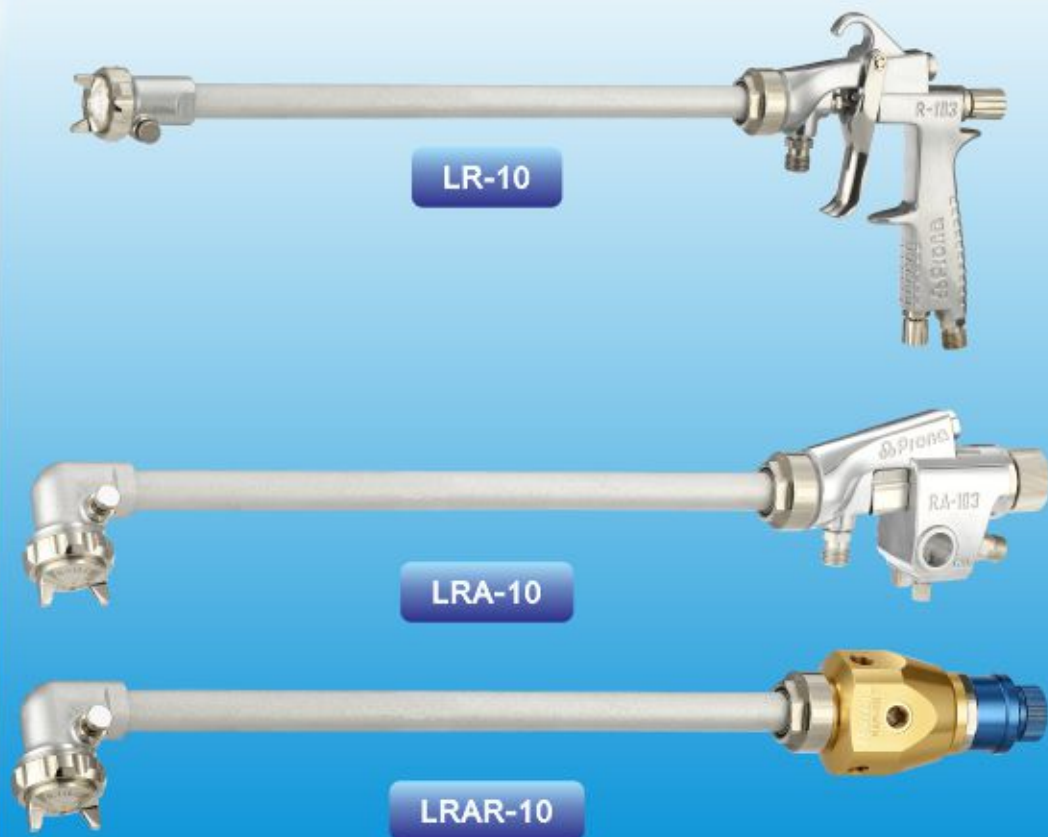
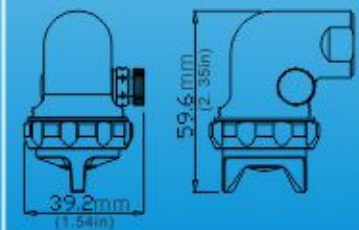

LR10(Manual)/LRA10(Automatic)/LRAR10(Automatic)

Special length can be ordered

Remark: LR10-P10-45 300

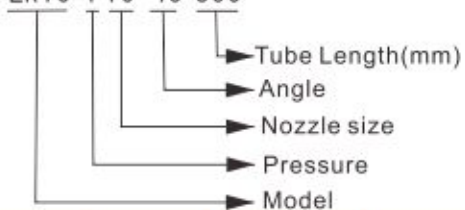

Model	Head angle	Nozzle size	Air cap	Air pressure	Air consumption	Fluid output	Headed length	Spray distance	Spray width ±20	Weight
	°	ømm (in)		kg/cm ² (Mpa)	l/min	ml/min	mm(in)	mm(in)	mm(in)	g(lbs)
LR10-P08	0°	0.8(0.031)	E2P	2.5-3.0 (0.24-0.29)	270	150	50(1.97)	200(7.87)	190(7.48)	540-887 (1.19-1.96)
LR10-P10	45°	1.0(0.039)			270	200	150(5.91)		220(8.66)	
LR10-P13	90°	1.3(0.051)			220	200	200(7.87)		210(8.27)	
LR10-P15	(Fixed Angle)	1.5(0.059)			220	250	300(11.81)		240(9.45)	
LRA10-P08	0°	0.8(0.031)	E2P	2.5-3.0 (0.24-0.29)	270	150	50(1.97)	200(7.87)	190(7.48)	764-1031 (1.68-2.27)
LRA10-P10	45°	1.0(0.039)			270	200	150(5.91)		220(8.66)	
LRA10-P13	90°	1.3(0.051)			220	200	200(7.87)		210(8.27)	
LRA10-P15	(Fixed Angle)	1.5(0.059)			220	250	300(11.81)		240(9.45)	
LRAR10-P08	0°	0.8(0.031)	E2P	2.5-3.0 (0.24-0.29)	270	150	50(1.97)	200(7.87)	190(7.48)	645-910 (1.42-2)
LRAR10-P10	45°	1.0(0.039)			270	200	150(5.91)		220(8.66)	
LRAR10-P13	90°	1.3(0.051)			220	200	200(7.87)		210(8.27)	
LRAR10-P15	(Fixed Angle)	1.5(0.059)			220	250	300(11.81)		240(9.45)	

◆LR-10 Fluid viscosity: 20±1 second/ RV-2. Coating pressure: 0.8kg/cm². Fluid and air inlet hose size: 1/4 PF/NPF.
 ◆LRA-10 Fluid viscosity: 20±1 second/ RV-2. Coating pressure: 0.8kg/cm². Fluid and air inlet hose size: 1/4 PF/NPF.
 ◆LRAR-10 Fluid viscosity: 20±1 second/ RV-2. Coating pressure: 0.8kg/cm². Fluid and air inlet hose size: 1/8 PF/NPF.



R-2200AC-A
Air cap set with protective cover

R-2200AC-B
Air cap set without protective cover

Functions and Characteristics

- ◆R-2200AC Air-assisted gun is a combination of traditional air spraying and airless spraying technology. It atomizes precisely to produce a stable coating spray surface. It can form a uniform coating surface on the workpiece with high transfer efficiency and fine spraying quality.
- ◆R-2200AC is recommended for spraying: varnishes, lacquers, colours, solvented and water-based paint, high solid materials paint, is also suitable for one component and two component paint.

Model	R-2200AC
Air Cap	R24
Maximum Working Air Pressure	6 bar (87psi)
Usage Fluid Pressure	200 bar(20Mpa , 2900 psi)
Fluid Output	Depending On Tip Size
Maximum Operating Temperature	50 °C
Air Consumption	385 L/min(±10)
Transfer Efficiency	87 (±2 %)
Wetted Parts	Stainless Steel
Fluid Connector	1/4 NPS , 360°Inline Filter Or Swivel Fitting
Air Connector	1/4PF
Safety Device	Safety Lever ,Protection Cap
Material Filter	Fluid Connector the Inline filter (100mesh)
Noise Level	80 dBa (±2)
Spray Distance	200mm
Weight	620g (1.37 lbs)

R-2200AC Testing conditions: paint pressure=60; viscosity=20 s; air pressure=1.5 bar; temperature=20 °C; relative humidity=60%

Detailed specification of nozzle please refer to page 76.



MRS-F(A)

MRS-R(A)

MRS2-F(B)

MRS2-R(B)

MRS1-F(B)

MRS1-R(B)

Mold Released Spray Gun

Application NO:201820637747.1

Functions and Characteristics

- ◆ Suitable for spraying mold release material, hydrographics activator, silver reaction solution, also the lubricant for industry fabrication.
- ◆ Both needle and nozzle are made of stainless steel.

Fluid needle set

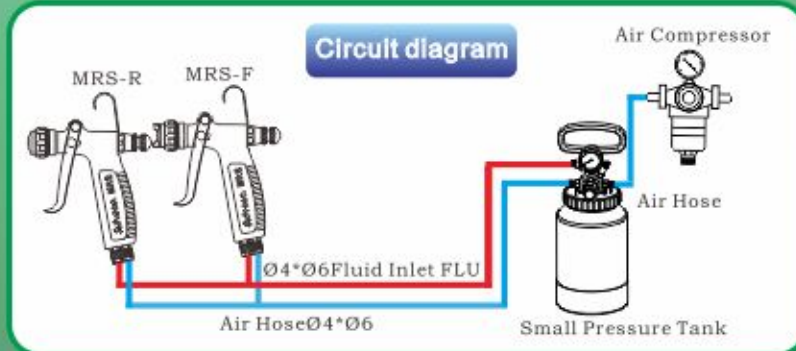
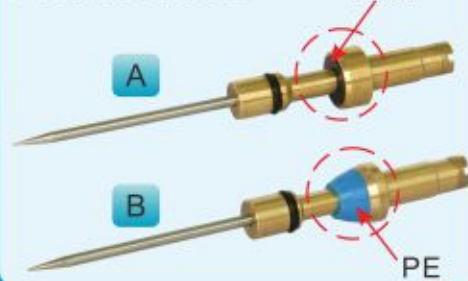

Model	Type of feed	Nozzle size	Air cap	Air pressure	Air consumption	Fluid output	Spray width ±10	Weight
		ømm (in)		kg/cm ² (Mpa)	l/min	ml/min	mm(in)	g(lbs)
MRS-F/ MRS1-F/ MRS2-F	Pressure	0.3(0.012)	03F	2.0(0.2)	35	5	120(4.72)	MRS-F:250(0.55) MRS2-F:320(0.7)
		0.5(0.020)	05F		40	20	160(6.30)	
		0.8(0.031)	08F		45	40	170(6.69)	
		1.0(0.039)	08F		45	55	175(6.89)	
		1.3(0.051)	08F		45	80	185(7.28)	
MRS-R/ MRS1-R/ MRS2-R	Pressure	0.3(0.012)	03R	2.0(0.2)	35	5	Round	MRS-R:250(0.55) MRS2-R:320(0.7)
		0.5(0.020)	05R		40	20		
		0.8(0.031)	08R		45	40		
		1.0(0.039)	10R		60	55		
		1.3(0.051)	13R		80	80		

◆ MRS/ MRS1 / MRS2-F/R spraying distance: 100-150mm (3.94-5.91in). Fluid viscosity: 9±1 second/ RV-2. Coating pressure: 0.8kg/cm². Fluid and air hose size: ø4 x ø6mm.

Double-headed Spray Gun

Application NO:201420622064.0

1. Needle, nozzle and cap are made of stainless steel.
2. Different size of nozzles and air caps are available.
3. Adjusting knob is easy to control.



MRS2-2R

Functions and Characteristics

1. Applicable for producing craftwork and decoration; making personalized wheel hub. Also suitable for spraying nano silver on cellphone or computer, achieve switching from traditional electroplating to nano spray plating.
2. Fluid output can be adjusted individually, ideal for spraying two different color or different component.
3. Fluid passage is made of high quality stainless steel, suitable for spraying corrosive coating.

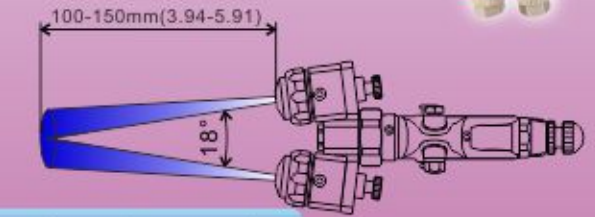

Various chroming samples



Circuit diagram

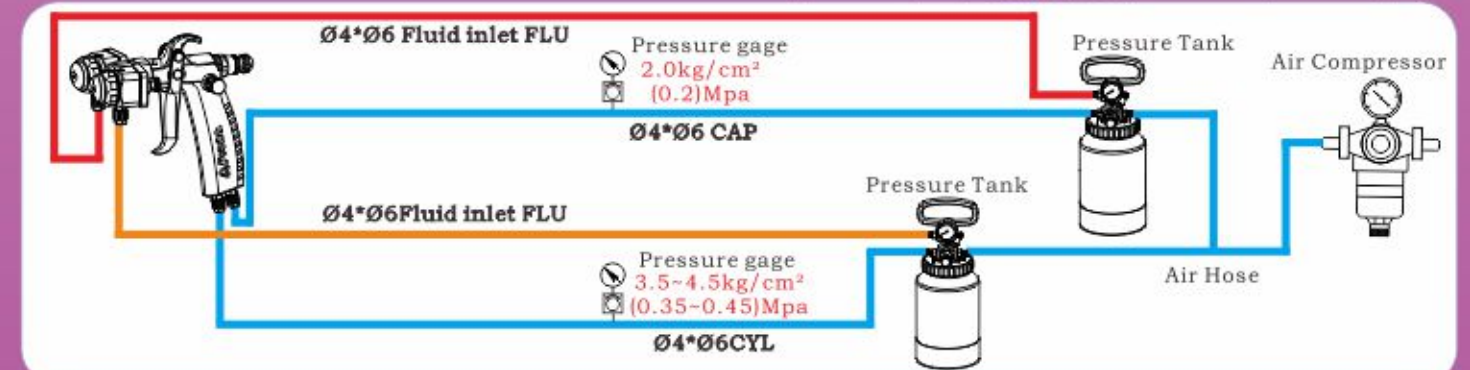

Model	Type of feed	Nozzle size	Air cap	Air pressure	Air consumption	Fluid output	Spray width ±10	Weight
		ømm (in)		kg/cm ² (Mpa)	l/min	ml/min	mm(in)	g(lbs)
MRS2-2R	Pressure	0.5(0.020)	05R	2.0(0.2)	55-75	40	Round	557 (1.23)
		0.8(0.031)	08R			80		
		1.0(0.039)	10R			120		
		1.3(0.051)	13R			150		

◆ MRS2-2R spraying distance: 100-150mm (3.94-5.91in). Fluid viscosity: 9±1 second/ RV-2. Fluid and air hose size: ø4 x ø6mm.



Functions and Characteristics

- ◆ The gun body is designed according to ergonomics, provide better control of operation.
- ◆ Provide fine atomization even in low air pressure and volume, ideal for painting small area, such as vehicle repair and art works.
- ◆ Has surface preparation for anodizing and sand blasting, is wear resistance, easy to clean and maintain.
- ◆ Needle and nozzle are made of stainless steel, featured with anti-corruption, abrasive and long service life.
- ◆ RL-90LN No air supply is needed.

Model	Type of feed	Nozzle size	Air cap	Air pressure	Air consumption	Fluid output	Spray width ±10	Weight
		ømm (in)		kg/cm ² (Mpa)	l/min	ml/min	mm(in)	g(lbs)
RL-90-LN/LN-A	Gravity	1.0(0.039)	-	-	-	50	-	282(11.10)
RL-90-F	Gravity	0.4(0.016)	04F	0.9-1.5 (0.09-0.15)	40	8	40(1.57)	280-340 (11.02-13.39)
RL-90-F-A		0.6(0.024)	06F			40	60(2.36)	
		0.8(0.031)	08F			60	80(3.15)	
		1.0(0.039)	10F			80	100(3.94)	
		1.2(0.047)	12F		100	115(4.53)		
RL-90-R1	Gravity	0.4(0.016)	04R1	0.9-1.5 (0.09-0.15)	50	7	25(1.97)	254-314 (0.56-12.36)
RL-90-R1-A		0.6(0.024)	06R1			40	35(1.38)	
		0.8(0.031)	08R1			60	40(1.57)	
		1.0(0.039)	10R1			80		
		1.2(0.047)	12R1			100		
RL-90R	Gravity	0.4(0.016)	04R	2.0-2.5 (0.2-0.24)	30	15	25(1.97)	329.2 (0.74)
		0.6(0.024)	06R			30	35(1.38)	
		0.8(0.031)	08R			50	38(1.50)	
		1.0(0.039)	10R			50	40(1.57)	

◆RL90-F/R/R1/A spraying distance: 150mm (5.91in). Fluid viscosity: 20±1 second/ RV-2. Fluid and air inlet: 1/4 PF/NPF.

Functions and Characteristics

- ◆The gun body is designed according to ergonomics, provide better control of operation.
- ◆Provide fine atomization even in low air pressure and volume, ideal for painting small area, such as vehicle repair and art works.
- Has surface preparation for anodizing and sand blasting, is wear resistance, easy to clean and maintain.
- ◆Needle and nozzle are made of stainless steel, featured with anti-corruption, abrasive and long service life.
- ◆The fluid passage of R53(S) is made of stainless steel.

Model	Type of Feed	Nozzle size	Air cap	Air pressure	Air consumption	Fluid output	Spray width ±10	Weight	
		ømm (in)		kg/cm ² (Mpa)	l/min	ml/min	mm(in)	g(lbs)	
RL-80F	Gravity	0.4(0.016)	04F	0.9-1.5 (0.09-0.15)	50	8	40(1.57)	254(0.56)	
		0.6(0.024)	06F			25	60(2.36)		
		0.8(0.031)	08F			50	80(3.15)		
		1.0(0.039)	10F			50	100(3.94)		
		1.2(0.047)	12F			50	115(4.53)		
RL-80R	Gravity	0.4(0.016)	04R	2.0-2.5 (0.2-0.24)	30	15	25(1.97)	270(0.6)	
		0.6(0.024)	06R			30	35(1.38)		
		0.8(0.031)	08R			50	38(1.50)		
		1.0(0.039)	10R			50	40(1.57)		
		1.2(0.047)	12R			50	65		40(1.57)
RL-80R1	Gravity	0.4(0.016)	04R1	0.9-1.5 (0.09-0.15)	50	7	25(1.97)	254(0.56)	
		0.6(0.024)	06R1			40	35(1.38)		
		0.8(0.031)	08R1			50	35(1.38)		
		1.0(0.039)	10R1			50	40(1.57)		
		1.2(0.047)	12R1			50	40(1.57)		
R-53(S)-G08	Gravity	0.8(0.031)	08/10	1.5-2.0 (0.15-0.20)	110	65	140(5.51)	405.8(0.89)	
R-53(S)-G10		1.0(0.039)	HVLP			110	85		145(5.71)
R-53(S)-G12		1.2(0.047)	12/14			130	110		160(6.30)
R-53(S)-G14		1.4(0.055)	HVLP			130	130		165(6.50)

◆RL80-F/R/R1/spraying distance: 150mm (5.91in). Fluid viscosity: 20±1 second/ RV-2. Fluid and air inlet: 1/4 PF/NPF.
◆R-53(S) spraying distance: 100-150mm (3.9-5.91in). Fluid viscosity: 20±1 second/ RV-2. Fluid and air inlet: 1/4 PF/NPF.



Functions and Characteristics

- ◆ Air cap is processed by high accuracy turn-milling technology, provide equal and steady atomization.
- ◆ Both needle and nozzle are made of stainless steel.
- ◆ The gravity cup is made of POM (plastic) provides excellent abration and corrosion resistance.
- ◆ Suitable for painting small area for automotive, toy and hardware industries.
- ◆ R2-G is a glue-injected gun, use for filling glue in narrow crevice or filling coating. For example, fill sole with glue.
- ◆ No air supply is needed. Special length of fluid pipe can be ordered

Model	Type of feed	Nozzle size	Air cap	Air pressure	Air consumption	Fluid output	Spray width ±10	Weight	Head length
		ømm (in)		kg/cm ² (Mpa)	l/min	ml/min	mm(in)	g(lbs)	mm(in)
R2-F	Pressure	0.3(0.013)	03F	1.8-2.5 (0.18-0.24)	30	6	50(1.97)	260(0.57)	-
		0.5(0.020)	05F		35	20	50(1.97)		
	Gravity	0.8(0.031)	08F		40	60	80(3.15)		
		1.0(0.039)	10F		45	80	100(3.97)		
R2-R	Gravity	0.5(0.020)	-	1.8-2.5 (0.18-0.24)	35	20	Round	-	
		0.8(0.031)			40	40			
R2-G	Pressure	0.5(0.020)	-	-	-	90	-	266(0.58)	A: 15 (0.59) / 30 (1.18) 50 (1.96) / 100 (3.93)
R3-F	Pressure	0.3(0.013)	03F	1.8-2.5 (0.18-0.24)	30	6	50(1.97)	293(0.65)	-
		0.5(0.020)	05F		35	20	50(1.97)		
	Gravity	0.8(0.031)	08F		40	60	80(3.15)		
		1.0(0.039)	10F		45	80	100(3.97)		
R3-R	Gravity	0.5(0.020)	05R	2.5(0.24)	35	20	Round	289(0.64)	-
		0.8(0.031)	08R		40	40			

- ◆R-2F Spraying distance: 150mm (5.91in). Fluid viscosity: 20±1 second/ RV-2. Fluid and air inlet: 1/4 PF/NPF.
- ◆R2-R Spraying distance: 150mm (5.91in). Fluid viscosity: 20±1 second/ RV-2. Fluid and air inlet: 1/4 PF/NPF.
- ◆R2-G: Fluid inlet 1/4PF/NPF. Fluid pressure 0.5-1kg/cm².
- ◆R3-F Spraying distance: 150mm (5.91in). Fluid viscosity: 20±1 second/ RV-2. Fluid and air inlet: 1/4 PF/NPF.
- ◆R3-R Spraying distance: 150mm (5.91in). Fluid viscosity: 20±1 second/ RV-2. Fluid and air inlet: 1/4 PF/NPF.

Functions and Characteristics

- ◆ Air cap is processed by high accuracy turn-milling technology, provide equal and steady atomization.
- ◆ Needle nozzle and fluid passage is made of stainless steel.
- ◆ The gravity cup is made of POM (plastic) provides excellent abration and corrosion resistance.
- ◆ Suitable for painting small area in automotive, toy and hardware industries.

Model	Type of feed	Nozzle size	Air cap	Air pressure	Air consumption	Fluid output	Spray width ±10	Weight
		ømm (in)		kg/cm ² (Mpa)	l/min	ml/min	mm(in)	g(lbs)
RG-3L	Gravity	0.4(0.016)	04R	2.0-2.5 (0.2-0.24)	30	15	25(1.97)	225(0.50)
		0.6(0.024)	06R		30	35	35(1.38)	
		0.8(0.031)	08R		50	60	38(1.50)	
		1.0(0.039)	10R		50	80	40(1.57)	
RL-50	Gravity	0.4(0.016)	04F	0.9-1.5 (0.09-0.15)	50	8	40(1.57)	245(0.54)
		0.6(0.024)	06F		50	25	60(2.36)	
		0.8(0.031)	08F		50	60	80(3.15)	
		1.0(0.039)	10F		50	80	100(3.94)	
RL-50-R1	Gravity	0.4(0.016)	04R1	0.9-1.5 (0.09-0.15)	30	7	25(1.97)	245(0.54)
		0.6(0.024)	06R1		50	40	35(1.38)	
		0.8(0.031)	08R1		50	60	35(1.38)	
		1.0(0.039)	10R1		50	80	40(1.57)	
R51-F	Pressure	0.3(0.012)	03F	2.0-2.5 (0.2-0.24)	35	6	120(4.72)	300(0.66)
		0.5(0.020)	05F		35	20	75(2.95)	
	Gravity	0.8(0.031)	08F		40	60	100(3.94)	
		1.0(0.039)	10F		45	80	120(4.72)	
R51-R	Pressure	0.3(0.012)	03R	2.0-2.5 (0.2-0.24)	35	6	Round	300(0.66)
		0.5(0.020)	05R		35	20		
	Gravity	0.8(0.031)	08R		40	60		
		1.0(0.039)	10R		45	80		

- ◆RG-3L Spraying distance: 200mm (7.87in). Fluid viscosity: 20±1 second/ RV-2. Fluid and air inlet: 1/4 PF/NPF.
- ◆RL-50 Spraying distance: 100-200mm (3.94-7.87in). Fluid viscosity: 20±1 second/ RV-2. Fluid and air inlet: 1/4 PF/NPF.
- ◆R-51F/R Spraying distance: 150mm (5.91in). Fluid viscosity: 20±1 second/ RV-2. Fluid and air inlet: 1/4 PF/NPF.



Functions and Characteristics

◆The needle and nozzle of R21X have high hardness after heat treatment, are wear-resistance and durable.

Model	Type of feed	Nozzle size	Air pressure	Air consumption	Fluid output	Spray width ±20	Weight
		ømm (in)	kg/cm ² (Mpa)	l/min	ml/min	mm(in)	g(lbs)
R-21X(N)-G13	Gravity	1.3(0.051)	2.5-3.0 (0.24-0.29)	170	200	210(8.27)	R-21X:420(0.93) R-21XN:485(1.07)
R-21X(N)-G15		1.5(0.059)		200	225	230(9.06)	
R-21X(N)-G20		2.0(0.079)		230	260	250(9.84)	
R-21X(N)-G25		2.5(0.098)		260	300	270(10.63)	
R-21X(N)-S13	Suction	1.3(0.051)	2.5-3.0 (0.24-0.29)	170	180	210(8.27)	R-21X:420(0.93) R-21XN:485(1.07)
R-21X(N)-S15		1.5(0.059)		200	200	230(9.06)	
R-21X(N)-S20		2.0(0.079)		230	230	250(9.84)	
R-21X(N)-S25		2.5(0.098)		260	270	270(10.63)	

◆R-21X(N) Spraying distance: 200mm (7.87in). Fluid viscosity: 20±1 second/ RV-2. Coating pressure: 0.8kg/cm². Fluid and air inlet: 1/4 PF/NPF.

Functions and Characteristics

- ◆The needle and nozzle of R21V have high hardness after heat treatment, are wear-resistance and durable.
- ◆Nozzles and needles are made of S1 stainless steel, suitable for water-based paints.

Model	Type of feed	Nozzle size	Air pressure	Air consumption	Fluid output	Spray width ±20	Weight
		ømm (in)	kg/cm ² (Mpa)	l/min	ml/min	mm(in)	g(lbs)
R-21V-G13	Gravity	1.3(0.051)	2.5-3.0 (0.24-0.29)	170	200	210(8.27)	R-21X:420(0.93) R-21XN:485(1.07)
R-21V-G15		1.5(0.059)		200	225	230(9.06)	
R-21V-G20		2.0(0.079)		230	260	250(9.84)	
R-21V-G25		2.5(0.098)		260	300	270(10.63)	
R-21V-S13	Suction	1.3(0.051)	2.5-3.0 (0.24-0.29)	170	180	210(8.27)	R-21X:420(0.93) R-21XN:485(1.07)
R-21V-S15		1.5(0.059)		200	200	230(9.06)	
R-21V-S20		2.0(0.079)		230	230	250(9.84)	
R-21V-S25		2.5(0.098)		260	270	270(10.63)	

◆R-21V Spraying distance: 200mm (7.87in). Fluid viscosity: 20±1 second/ RV-2. Coating pressure: 0.8kg/cm². Fluid and air inlet: 1/4 PF/NPF.

R-71
Suction
With RC-2 Cup
(RC-6DC S2 Cup)



R-71N
Suction
With RC-2 Cup
(RC-6DC S2 Cup)



R-77
Suction
With RC-1 Cup
(RC-6DC S1 Cup)



R-77N
Suction
With RC-1 Cup
(RC-6DC S1 Cup)



R-71
Gravity
With RC-4SR Cup



R-71N
Gravity
With RC-4SR Cup



R-77
Gravity
With RC-4R Cup



R-77N
Gravity
With RC-4R Cup



Functions and Characteristics

- ◆ The needle and nozzle of R71 have high hardness after heat treatment, are wear-resistance and durable.
- ◆ The fluid passage, needle and nozzle of R71N are made of stainless steel, ideal for water based paint.

Model	Type of feed	Nozzle size	Air pressure	Air consumption	Fluid output	Spray width ±20	Weight
		ømm (in)	kg/cm ² (Mpa)	l/min	ml/min	mm(in)	g(lbs)
R-71(N)-G10	Gravity	1.0(0.039)	2.5-3.0 (0.24-0.29)	75	110	120(4.74)	496(1.09)
R-71(N)-G13		1.3(0.051)		195	160	165(6.50)	
R-71(N)-G15		1.5(0.059)		230	190	185(7.28)	
R-71(N)-G18		1.8(0.071)		250	260	210(8.27)	
R-71(N)-S10	Suction	1.0(0.039)	2.5-3.0 (0.24-0.29)	75	95	100(3.94)	496(1.09)
R-71(N)-S13		1.3(0.051)		195	140	155(6.10)	
R-71(N)-S15		1.5(0.059)		230	170	170(6.69)	
R-71(N)-S18		1.8(0.071)		250	220	180(7.09)	
R-71(N)-P08	Pressure	0.8(0.031)	2.5-3.0 (0.24-0.29)	240	200	190(7.48)	496(1.09)
R-71(N)-P10		1.0(0.051)		230	300	265(10.43)	

◆R-71(N) Spraying distance: 200mm (7.87in). Fluid viscosity: 20±1 second/ RV-2. Coating pressure: 0.8kg/cm2. Fluid and air inlet: 1/4 PF/NPF.

Functions and Characteristics

- ◆ The needle and nozzle of R77 have high hardness after heat treatment, are wear-resistance and durable.
- ◆ The fluid passage, needle and nozzle of R77N are made of stainless steel, ideal for water based paint.

Model	Type of feed	Nozzle size	Air pressure	Air consumption	Fluid output	Spray width ±20	Weight
		ømm (in)	kg/cm ² (Mpa)	l/min	ml/min	mm(in)	g(lbs)
R-77(N)-G15	Gravity	1.5(0.059)	3.0-3.5 (0.29-0.34)	290	270	290(11.42)	590(1.3)
R-77(N)-G20		2.0(0.079)		360	440	320(12.60)	
R-77(N)-G25		2.5(0.098)		460	520	320(13)	
R-77(N)-S15	Suction	1.5(0.059)	3.0-3.5 (0.29-0.34)	290	250	260(10.24)	590(1.3)
R-77(N)-S20		2.0(0.079)		360	370	290(11.42)	
R-77(N)-S25		2.5(0.098)		460	440	300(11.81)	
R-77(N)-S30		3.0(0.118)		460	480	320(13)	
R-77(N)-P12	Pressure	1.2(0.047)	3.0-3.5(0.29-0.34)	430	480	380(14.96)	590(1.3)

◆R-77(N) Spraying distance: 250mm (9.84in). Fluid viscosity: 20±1 second/ RV-2. Coating pressure: 0.8kg/cm2. Fluid inlet: 3/8 PF/NPF. Air inlet: 1/4 PF/NPF.



Functions and Characteristics

- ◆ Featuring light-weight forged aluminium gun body which provide comfortable holding operation. Surface has processed by anodizing , easy to clean and maintain.
- ◆ Needle and nozzle are made of S1 stainless steel, suitable for water based paint.

Model	Type of feed	Nozzle size	Air pressure	Air consumption	Fluid output	Spray width ±20	Weight
		ømm(in)	kg/cm ² (Mpa)	l/min	ml/min	mm(in)	g(lbs)
R-711-G10	Gravity	1.0(0.039)	3.0(0.29)	75	110	120(4.74)	453(1.00)
R-711-G13		1.3(0.051)		195	160	165(6.50)	
R-711-G15		1.5(0.059)		230	190	185(7.28)	
R-711-G18		1.8(0.071)		250	260	210(8.72)	
R-711-S10	Suction	1.0(0.039)	3.5(0.34)	75	95	100(3.94)	453(1.00)
R-711-S13		1.3(0.051)		195	140	155(6.10)	
R-711-S15		1.5(0.019)		230	170	170(6.69)	
R-711-S18		1.8(0.071)		250	220	180(7.09)	
R-711-P08	Pressure	0.8(0.031)	3.0(0.29)	240	200	190(7.48)	453(1.00)
R-711-P10		1.0(0.039)		230	300	265(10.43)	

◆R-711 Spraying distance: 200mm (7.87in). Fluid viscosity: 20±1 second/ RV-2. Coating pressure: 0.8kg/cm². Fluid and air inlet: 1/4 PF/NPF.

Functions and Characteristics

- ◆ Featuring light-weight forged aluminium gun body which provide comfortable holding operation. Surface has processed by anodizing , easy to clean and maintain.
- ◆ Needle and nozzle are made of S1 stainless steel, suitable for water based paint.

Model	Type of feed	Nozzle size	Air pressure	Air consumption	Fluid output	Spray width ±20	Weight
		ømm(in)	kg/cm ² (Mpa)	l/min	ml/min	mm(in)	g(lbs)
R-771-G15	Gravity	1.5(0.059)	3.0-3.5 (0.29-0.34)	290	270	290(11.42)	462(1.02)
R-771-G20		2.0(0.079)		360	440	320(12.60)	
R-771-G25		2.5(0.098)		460	520	320(13)	
R-771-S15	Suction	1.5(0.059)	3.0-3.5 (0.29-0.34)	290	250	260(10.24)	462(1.02)
R-771-S20		2.0(0.079)		360	370	290(11.42)	
R-771-S25		2.5(0.098)		460	440	300(11.81)	
R-771-P12	Pressure	1.2(0.047)	3.0-3.5(0.29-0.34)	430	480	380(14.96)	462(1.02)

◆R-771 Spraying distance: 250mm (9.84in). Fluid viscosity: 20±1 second/ RV-2. Coating pressure: 0.8kg/cm². Fluid inlet: 3/8 PF/NPF. Air inlet: 1/4 PF/NPF.



R-100 P
Pressure



R-100 G
Gravity
With RC-4SR Cup



R-100 S
Suction
With RC-2 CUP
(RC-6DC S2 Cup)

Functions and Characteristics

- ◆ Air pressure can be adjusted freshly from 2.5 ~ 3.0 bar, for less over-spray and paint consumption .
- ◆ Featuring large fan pattern, provide fine atomization, high transfer efficiency and fast application speed.
- ◆ Light weight gun body and soft touch trigger provide better control of operation .
- ◆ Needle, nozzle and material passage are made of stainless steel, suitable for waterborne material.
- ◆ Different size of nozzles and air caps are available.

Model	Type of feed	Nozzle size	Air cap	Air pressure	Air consumption	Fluid output	Spray width ±20	Weight	Use
		ømm (in)		kg/cm ² (Mpa)	l/min	ml/min	mm(in)	g(lbs)	
R-100-P08	Pressure	0.8(0.031)	E2P	2.0-3.0 (0.20-0.29)	270	150	190(7.74)	407 (0.9)	Automobile, furniture and industry
R-100-P10		1.0(0.039)							
R-100-P13		1.3(0.051)							
R-100-P15		1.5(0.059)							
R-100-G10	Gravity	1.0(0.039)	E1	2.0-3.0 (0.20-0.29)	270	150	190(7.74)	407 (0.9)	Automobile, furniture and industry
R-100-G10		1.0(0.039)	E2						
R-100-G13		1.3(0.051)	K1						
R-100-G13		1.3(0.051)	H2						
R-100-G13		1.3(0.051)	H4						
R-100-G15		1.5(0.059)	K1						
R-100-G15		1.5(0.059)	H2						
R-100-G18		1.8(0.071)	N2						
R-100-S10	Suction	1.0(0.039)	E1	2.0-3.0 (0.20-0.29)	220	200	210(8.27)	407 (0.9)	Woodwork, furniture and metalwork.
R-100-S10		1.0(0.039)	E2						
R-100-S13		1.3(0.051)	K1						
R-100-S13		1.3(0.051)	H2						
R-100-S13		1.3(0.051)	H4						
R-100-S15		1.5(0.059)	K1						
R-100-S15		1.5(0.059)	H2						
R-100-S18		1.8(0.071)	N2						
R-100-S10		1.0(0.039)	E1						
R-100-S10		1.0(0.039)	E2						

◆R-100 Spraying distance: 200mm (7.87in). Fluid viscosity: 20±1 second/ RV-2. Coating pressure: 0.8kg/cm². Fluid and air inlet: 1/4 PF/NPF.

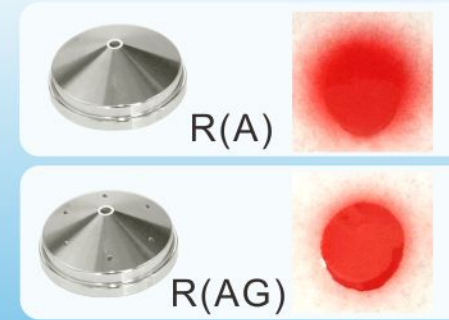

R-101
Circle Dot
Spray Gun



R-101 G
Gravity
with RC-4SR Cup



R-101 S
Suction
With RC-2 Cup
(RC-6DC S2 Cup)

Model	Type of feed	Nozzle size	Air cap	Air pressure	Air consumption	Fluid output	Spray width ±20	Weight	Use
		ømm (in)		kg/cm ² (Mpa)	l/min	ml/min	mm(in)	g(lbs)	
R-101-P08	Pressure	0.8(0.031)	E2P	2.0-3.0 (0.20-0.29)	270	150	190(7.48)	407 (0.9)	Automobile, furniture and industry
R-101-P10		1.0(0.039)							
R-101-P13		1.3(0.051)							
R-101-P15		1.5(0.059)							
R-101-G10	Gravity	1.0(0.039)	E1	2.0-3.0 (0.20-0.29)	220	200	210(8.27)	407 (0.9)	Woodwork, furniture and metalwork.
R-101-G10		1.0(0.039)	E2						
R-101-G13		1.3(0.051)	K1						
R-101-G13		1.3(0.051)	H2						
R-101-G13		1.3(0.051)	H4						
R-101-G15		1.5(0.059)	K1						
R-101-G15		1.5(0.059)	H2						
R-101-G18		1.8(0.071)	N2						
R-101-S10	Suction	1.0(0.039)	E1	2.0-3.0 (0.20-0.29)	220	200	210(8.27)	407 (0.9)	Woodwork, furniture and metalwork.
R-101-S10		1.0(0.039)	E2						
R-101-S13		1.3(0.051)	K1						
R-101-S13		1.3(0.051)	H2						
R-101-S13		1.3(0.051)	H4						
R-101-S15		1.5(0.059)	K1						
R-101-S15		1.5(0.059)	H2						
R-101-S18		1.8(0.071)	N2						
R-101-S10		1.0(0.039)	E1						
R-101-S10		1.0(0.039)	E2						
R-101-05R	Interchangeable	0.5(0.020)	05R	2.0-3.0 (0.20-0.29)	220	200	210(8.27)	407 (0.9)	Automobile, furniture and industry
R-101-08R		0.8(0.031)	08R						
R-101-10R		1.0(0.039)	08R						
R-101-13R		1.3(0.051)	08R						
R-101-15R		1.5(0.059)	08R						
R-101-18R		1.8(0.031)	18R						
R-101-10R		1.0(0.039)	08R						
R-101-13R		1.3(0.051)	08R						

◆R-101 Spraying distance: 200mm (7.87in). Fluid viscosity: 20±1 second/ RV-2. Coating pressure: 0.8kg/cm². Fluid and air inlet: 1/4 PF/NPF.

R-103-E2P Spray pattern



R-103 P Pressure



R-103 G Gravity With RC-4SR Cup



R-103 S Suction With RC-2 Cup (RC-6DC S2 Cup)



R-200 P Pressure



R-200 G Gravity With RC-4R Cup



R-200 S Suction With RC-1 Cup (RC-6DC S1 Cup)

Functions and Characteristics

- ◆ This spray gun provide fine and even atomization; can easily achieve excellent performance.
- ◆ The light-weight gun body is designed according to ergonomics, for better control of operation.
- ◆ Polished gun body is easy to clean and maintain.
- ◆ Wide spray pattern is easy to adjusted, can achieve higher efficiency.
- ◆ Material saving technology, can reduce paint consumption, cost and environmental pollution.
- ◆ Spare parts are made of great quality material, featured with anti-corruption, abrasive and long service life.
- ◆ All spare parts are easy to install, air cap can be changed and cleaned easily.

Functions and Characteristics

- ◆ Air pressure can be adjusted freshly 2.5 ~ 3.0 bar, less over-spray and paint consumption.
- ◆ Featuring large fan pattern, fine atomization, high transfer efficiency and fast application speed.
- ◆ Light weight gun body and soft touch trigger provide comfortable operation.
- ◆ Needle, nozzle and material passage are made of stainless steel, suitable for waterborne material.
- ◆ Different size of nozzles and air caps are available.

Model	Type of feed	Nozzle size	Air cap	Air pressure	Air consumption	Fluid output	Spray width ±20	Weight	Use					
		ømm (in)		kg/cm ² (Mpa)	l/min	ml/min	mm(in)	g(lbs)						
R-103-P08	Pressure	0.8(0.031)	E2P	2.0-3.0 (0.20-0.29)	270	150	190(7.74)	433 (0.95)	Automobile, furniture and industry					
R-103-P10		1.0(0.039)				200	220(8.66)							
R-103-P13		1.3(0.051)				200	210(8.27)							
R-103-P15		1.5(0.059)				220	250			240(9.45)				
R-103-G10	Gravity	1.0(0.039)	E1	2.0-3.0 (0.20-0.29)	210-250	75	130(5.12)	433 (0.95)	Light industry. Automobile, furniture and industry					
R-103-G10		1.0(0.039)	E2			95	200(7.87)							
R-103-G13		1.3(0.051)	K1			145	170(6.69)							
R-103-G13		1.3(0.051)	H2			145	175(6.89)							
R-103-G13		1.3(0.051)	H4			160	175(6.89)							
R-103-G15		1.5(0.059)	K1			160	180(7.09)							
R-103-G15		1.5(0.059)	H2			200	190(7.48)							
R-103-G18		1.8(0.071)	N2			190	190(7.48)							
R-103-S10	Suction	1.0(0.039)	E1	2.0-3.0 (0.20-0.29)	210-250	75	120(4.72)	433 (0.95)	Light industry. Automobile, furniture and industry					
R-103-S10		1.0(0.039)	E2			85	200(7.87)							
R-103-S13		1.3(0.051)	K1			150	155(6.10)							
R-103-S13		1.3(0.051)	H2			150	160(6.30)							
R-103-S13		1.3(0.051)	H4			150	180-200(7.09-7.87)							
R-103-S15		1.5(0.059)	K1			175	170(6.69)							
R-103-S15		1.5(0.059)	H2			170	175(6.89)							
R-103-S18		1.8(0.071)	N2			210	170(6.69)							
														Woodwork, furniture and metalwork
														Automobile, furniture and industry

◆R-102 Spraying distance: 200mm (7.87in). Fluid viscosity: 20±1 second/ RV-2. Coating pressure: 0.8kg/cm². Fluid and air inlet: 1/4 PF/NPF.

Model	Type of feed	Nozzle size	Air cap	Air pressure	Air consumption	Fluid output	Spray width ±20	Weight	Use
		ømm (in)		kg/cm ² (Mpa)	l/min	ml/min	mm(in)	g(lbs)	
R-200-P08	Pressure	0.8(0.031)	G2P	2.5-3.0 (0.24-0.29)	560	400	350(13.78)	503 (1.10)	Extensive painting
R-200-P10		1.0(0.039)	G2P		560	400	350(13.78)		
R-200-P12		1.2(0.047)	G2P		560	500	400(15.75)		
R-200-G15	Gravity	1.5(0.059)	K1	2.5-3.0 (0.24-0.29)	200	270	220(8.66)	503 (1.10)	Automobile and industry
R-200-G15		1.5(0.059)	K2		330	270	340(13.39)		
R-200-G18		1.8(0.071)	K2		290	290	340(13.39)		
R-200-G20		2.0(0.079)	R1		260	410	280(11.02)		
R-200-G20		2.0(0.079)	R2		360	410	320(12.6)		
R-200-G25		2.5(0.098)	W2		360	510	330(13)		
R-200-S15	Suction	1.5(0.059)	K1	2.5-3.0 (0.24-0.29)	200	240	210(8.27)	503 (1.10)	Automobile and industry
R-200-S15		1.5(0.059)	K2		330	340	290(11.42)		
R-200-S18		1.8(0.071)	K2		330	290	340(13.39)		
R-200-S20		2.0(0.079)	R1		260	350	260(10.24)		
R-200-S20		2.0(0.079)	R2		360	350	290(11.26)		
R-200-S25	2.5(0.10)	W2	360	440	280(11.02)				

◆R-200 Spraying distance: 250mm (9.84in). Fluid viscosity: 20±1 second/ RV-2. Coating pressure: 0.8kg/cm². Fluid inlet: 3/8 PF/NPF. Air inlet: 1/4 PF/NPF.

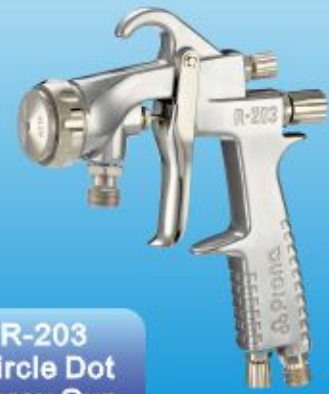

R-203 Circle Dot Spray Gun



R-203 G Gravity With RC-4R Cup



R-203 S Suction With RC-1 Cup (RC-6DC S1 Cup)



R303-N2 Spray pattern



R-303 G Gravity With RC-6M Cup (RC-6DC G1 Cup)



R-403 G Gravity With RC-6M Cup (RC-6DC G1 Cup)

Functions and Characteristics

- ◆ This spray gun provide fine and even atomization; can easily achieve excellent performance.
- ◆ The light-weight gun body is designed according to ergonomics, for better control of operation.
- ◆ Polished gun body is easy to clean and maintain.
- ◆ Wide spray pattern is easy to adjusted, can achieve higher efficiency.
- ◆ Material saving technology, can reduce paint consumption, cost and environmental pollution.
- ◆ Parts are made of great quality material, featured with anti-corruption, abrasive and long service life.
- ◆ All the spare parts are easy to install, air cap can be changed and cleaned easily.

Functions and Characteristics

- ◆ Provide finer atomization and homogeneous spray pattern, reduce over spray in low air pressure.
- ◆ The knob design provides easy adjustment.
- ◆ Fluid liner insider the fluid cup support better atomization and steable performance.
- ◆ Nozzle and needle are made of stainless steel, suitable for water-based paints.

Model	Type of feed	Nozzle size	Air cap	Air pressure	Air consumption	Fluid output	Spray width ±20	Weight	Use
		ømm(in)		kg/cm ² (Mpa)	l/min	ml/min	mm(in)	g(lbs)	
R-203-P08	Pressure	0.8(0.031)	G2P	2.5-3.0 (0.24-0.29)	560	400	350(13.78)	529 (1.17)	Extensive painting
R-203-P10		1.0(0.039)	G2P		560	400	350(13.78)		
R-203-P12		1.2(0.047)	G2P		560	500	400(15.75)		
R-203-G15	Gravity	1.5(0.059)	K1	2.5-3.0 (0.24-0.29)	200	270	220(8.66)	529 (1.17)	Automobile and industry
R-203-G15		1.5(0.059)	K2		330	270	340(13.39)		
R-203-G18		1.8(0.071)	K2		290	290	340(13.39)		
R-203-G20		2.0(0.079)	R1		260	410	280(11.02)		
R-203-G20		2.0(0.079)	R2		360	410	320(12.6)		
R-203-G25		2.5(0.098)	W2		360	510	330(13)		
R-203-S15	Suction	1.5(0.059)	K1	2.5-3.0 (0.24-0.29)	200	240	210(8.27)	529 (1.17)	Automobile and industry
R-203-S15		1.5(0.059)	K2		330	240	290(11.42)		
R-203-S18		1.8(0.071)	K2		290	290	340(13.39)		
R-203-S20		2.0(0.079)	R1		260	350	260(10.24)		
R-203-S20		2.0(0.079)	R2		360	350	290(11.42)		
R-203-S25	2.5(0.098)	W2	360	510	330(13)				
R-203-15R	All 3 tipes	1.5(0.059)	15R	2.5-3.0 (0.24-0.29)	270	325	90(3.54)	504 (1.11)	Automobile and industry
R-203-18R		1.8(0.059)	15R		290	425	105(4.13)		
R-203-20R		2.0(0.071)	20R		360	470	110(4.33)		
R-203-25R		2.5(0.098)	25R		360	460	110(4.33)		

◆R-203 Spraying distance: 250mm (9.84in). Fluid viscosity: 20±1 second/ RV-2. Coating pressure: 0.8kg/cm2. Fluid inlet: 3/8 PF/NPF. Air inlet: 1/4 PF/NPF.

Model	Type of feed	Nozzle size	Air cap	Air pressure	Air consumption	Fluid output	Spray width ±20	Weight	Use			
		ømm(in)		kg/cm ² (Mpa)	l/min	ml/min	mm(in)	g(lbs)				
R-303-G10	Gravity	1.0(0.039)	E1	2.0-2.5 (0.2-0.24)	75	175	130(5.12)	430 (0.95)	Light industry			
R-303-G10		1.0(0.039)	E2		145	150	200(7.87)		Automobile, furniture and industry			
R-303-G13		1.3(0.051)	K1		145	280	170(6.69)		Woodwork, furniture and metalwork			
R-303-G13		1.3(0.051)	H2		225	200	175(6.89)		Woodwork, furniture and industry			
R-303-G13		1.3(0.051)	H4		210-250	200	205-220(8.07-8.66)		Woodwork, furniture and industry			
R-303-G15		1.5(0.059)	K1		145	335	180(7.09)		Woodwork, furniture and metalwork			
R-303-G15		1.5(0.059)	H2		225	235	190(7.48)		Woodwork, furniture and industry			
R-303-G18		1.8(0.071)	N2		150	280	190(7.48)		Woodwork, furniture and metalwork			
R-403-G12		Gravity	1.2(0.047)		LV2	2.0-3.0 (0.2-0.29)	320		160	230-250(9.06-9.84)	517 (1.14)	Automobile
R-403-G13			1.3(0.051)		LV2		320		180	240-260(9.45-10.24)		Automobile
R-403-G14	1.4(0.055)		LV2	320	215		250-275(9.84-10.82)	Automobile, furniture and industry				
R-403-G15	1.5(0.059)		LV2	320	270		260-280(10.24-11.02)	Automobile				
R-403-G16	1.6(0.063)		LV2	320	275		300-340(11.81-13.39)	Automobile, furniture and industry				
R-403-G18	1.8(0.071)		LV2	320	330		330-355(12.99-13.98)	Middle viscosity painting, metalwork and woodwork				
R-403-G20	2.0(0.079)		R2	360	410		320(12.60)	Best coat, high viscosity painting				
R-403-G25	2.5(0.098)		W1	360	580		340(13.39)	High Viscosity painting, metalwork and woodwork.				
R-403-G25	2.5(0.098)		W2	360	510		320(12.60)					

◆R-303 Spraying distance: 200mm (7.87in). Fluid viscosity: 20±1 second/ RV-2. Fluid inlet: M16X1.5P. Air inlet: 1/4 PF/NPF.
 ◆R-403 Spraying distance: 250mm (9.84in). Fluid viscosity: 20±1 second/ RV-2. Fluid inlet: M16X1.5P. Air inlet: 1/4 PF/NPF.

R3300(Ø1.7) Spray pattern



R-3300 Gravity With RC-6M Cup (RC-6DC G1 Cup)

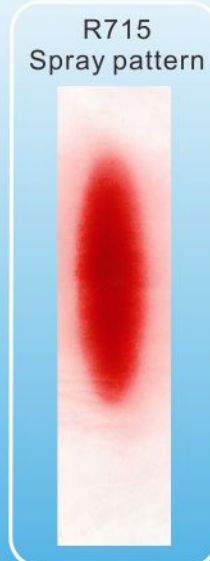

R715 Spray pattern



R-715 Suction With RC-2 Cup (RC-6DC S2 Cup)



R775 Spray pattern



R-775 Suction With RC-1 Cup (RC-6DC S1 Cup)



R-715 Gravity With RC-4SR Cup



R-775 Gravity With RC-4R Cup

Functions and Characteristics

- ◆ The gun body is designed according to ergonomics, ensure beautiful lines for triggers and provide comfortable holding operation.
- ◆ This spray gun provide fine atomization, wider spray pattern suitable for automotive industries.
- ◆ Nozzle and needle are made of high quality stainless steel, suitable for water base paint and solvent.

Model	Type of feed	Nozzle size	Air cap	Air pressure	Air consumption	Fluid output	Spray width ±20	Weight
		ømm (in)		kg/cm ² (Mpa)	l/min	ml/min	mm(in)	g(lbs)
R-3300-G10	Gravity	1.0(0.039)	-	3.5-4.0 (0.34-0.39)	380	220	200(7.87)	515(1.36)
R-3300-G13		1.3(0.051)				300	220(8.66)	
R-3300-G14		1.4(0.055)				320	235(9.25)	
R-3300-G15		1.5(0.059)				340	250(9.84)	
R-3300-G17		1.7(0.067)				400	280(11.02)	
R-3300-G20		2.0(0.078)				480	310(12.20)	

◆R-3300 Spraying distance: 250mm (9.84in). Fluid viscosity: 20±1 second/ RV-2. Fluid inlet: M16X1.5P. Air inlet: 1/4 PF/NPF.

Functions and Characteristics

- ◆ Light weight forged aluminium gun body provides better control of operation. Anodizing and sand blasting, surface is easy to clean and maintain.
- ◆ The nozzle and needle are made of S1 stainless steel, suitable for water-based paints.

Model	Type of feed	Nozzle size	Air pressure	Air consumption	Fluid output	Spray width ±20	Weight
		ømm (in)	kg/cm ² (Mpa)	l/min	ml/min	mm(in)	g(lbs)
R-715-G10	Gravity	1.0(0.039)	3.0(0.29)	75	110	120(4.74)	496(1.09)
R-715-G13		1.3(0.051)		195	160	165(6.50)	
R-715-G15		1.5(0.059)		230	190	185(7.28)	
R-715-G18		1.8(0.071)		250	260	210(8.72)	
R-715-S10	Suction	1.0(0.039)	3.5(0.34)	75	95	100(3.94)	496(1.09)
R-715-S13		1.3(0.051)		195	140	155(6.10)	
R-715-S15		1.5(0.019)		230	170	170(6.69)	
R-715-S18		1.8(0.071)		250	220	180(7.09)	
R-715-P08	Pressure	0.8(0.031)	3.0(0.29)	240	200	190(7.48)	496(1.09)
R-715-P10		1.0(0.039)		230	300	265(10.43)	
R-775-G15	Gravity	1.5(0.059)	3.5(0.34)	290	270	290(11.42)	534(1.18)
R-775-G20		2.0(0.079)		360	440	320(12.60)	
R-775-G25		2.5(0.098)		460	520	320(12.60)	
R-775-S15	Suction	1.5(0.059)	3.5(0.34)	290	250	260(10.24)	534(1.18)
R-775-S20		2.0(0.079)		360	370	290(11.42)	
R-775-S25		2.5(0.098)		460	440	300(11.81)	
R-775-P12	Pressure	1.2(0.047)	3.5(0.34)	430	480	380(14.96)	534(1.18)

◆R-715 Spraying distance: 200mm (7.87in). Fluid viscosity: 20±1 second/ RV-2. Coating pressure: 0.8kg/cm². Fluid and air inlet: 1/4 PF/NPF.

◆R-775 Spraying distance: 250mm (9.84in). Fluid viscosity: 20±1 second/ RV-2. Coating pressure: 0.8kg/cm². Fluid inlet: 3/8 PF/NPF. Air inlet: 1/4 PF/NPF.

R110-H2
Spray pattern



Functions and Characteristics

- ◆ This spray gun provide fine atomization; easily achieve excellent performance.
- ◆ Featuring light-weight forged aluminium gun body which provide comfortable holding operation. Surface has processed by anodizing and sand blasting, easy to clean and maintain.
- ◆ The gun body is designed according to ergonomics, ensure beautiful lines for triggers and provide comfortable holding operation.
- ◆ Material paint saving technology can reduce paint consumption, cost and environmental pollution.
- ◆ Parts are made of great quality material, featured with anti-corruption, abrasive and long service life.
- ◆ Wide spray pattern can help achieve higher efficiency.

Model	Type of feed	Nozzle size	Air cap	Air pressure	Air consumption	Fluid output	Spray width ±20	Weight	Use	
		ømm (in)		kg/cm ² (Mpa)		ml/min	mm(in)	g(lbs)		
R-110-P08	Pressure	0.8(0.031)	E2P	2.5-3.0 (0.24-0.29)	270	150	190(7.74)	476 (1.05)	Automobile, furniture and industry	
R-110-P10		1.0(0.039)				200	220(8.66)			
R-110-P13		1.3(0.051)				200	210(8.27)			
R-110-P15		1.5(0.059)				250	240(9.45)			
R-110-G10	Gravity	1.0(0.039)	E1	2.5(0.24)	75	95	130(5.12)	476 (1.05)	Light industry	
R-110-G10		1.0(0.039)	E2			145	95			200(7.87)
R-110-G13		1.3(0.051)	K1			145	160			170(6.69)
R-110-G13		1.3(0.051)	H2			225	160			175(6.89)
R-110-G13		1.3(0.051)	H4			210-250	155-170			205-220(8.07-8.66)
R-110-G15		1.5(0.059)	K1			145	200			180(7.09)
R-110-G15		1.5(0.059)	H2			225	190			190(7.48)
R-110-G18		1.8(0.071)	N2			150	240			190(7.48)
R-110-S10	Suction	1.0(0.039)	E1	2.5(0.24)	75	85	120(4.72)	476 (1.05)	Light industry	
R-110-S10		1.0(0.039)	E2			130	85			200(7.87)
R-110-S13		1.3(0.051)	K1			145	150			155(6.10)
R-110-S13		1.3(0.051)	H2			225	150			160(6.30)
R-110-S13		1.3(0.051)	H4			210-250	140-150			180-200(7.09-7.87)
R-110-S15		1.5(0.059)	K1			145	175			170(6.69)
R-110-S15		1.5(0.059)	H2			225	170			175(6.89)
R-110-S18		1.8(0.071)	N2			150	210			170(6.69)

◆R-110 Spraying distance: 200mm (7.87in). Fluid viscosity: 20±1 second/ RV-2. Coating pressure: 0.8kg/cm². Fluid and air inlet: 1/4 PF/NPF.



R-210 P Pressure



R-210 S Suction With RC-1 Cup (RC-6DC S1 Cup)

PN16300PPS
Compatible with
3M® PPS system cups



R-210 G Gravity With RC-4R Cup

- Air cap is processed by high accuracy turn-milling technology, provide equal and steady atomization.
- Extended adjusting knob adopted the special thread design, can be adjusted faster and provide more comfortable hand feeling.
- The gun body is designed according to ergonomics, ensure beautiful lines for triggers and provide comfortable holding operation. Featuring forged aluminium gun body, no internal porosity, easy to clean and maintain.
- Trigger is made of anti-corruption and abrasive stainless steel, features a soft-touch rear trigger for comfortable operation.



Model	Type of feed	Nozzle size	Air cap	Air pressure	Air consumption	Fluid output	Spray width ±20	Weight	Use
		ømm (in)		kg/cm ² (Mpa)	l/min	ml/min	mm(in)	g(lbs)	
R-210-P08	Pressure	0.8(0.031)	G2P	2.5-3.0 (0.24-0.29)	560	400	350(13.78)	536 (1.18)	Extensive painting
R-210-P10		1.0(0.039)	G2P		560	400	350(13.78)		
R-210-P12		1.2(0.047)	G2P		560	500	400(15.75)		
R-210-G15	Gravity	1.5(0.059)	K1	2.5-3.0 (0.24-0.29)	200	270	220(8.66)	536 (1.18)	Automobile and industry
R-210-G15		1.5(0.059)	K2		330	270	340(13.39)		
R-210-G18		1.8(0.071)	K2		290	290	340(13.39)		
R-210-G20		2.0(0.079)	R1		260	410	280(11.02)		
R-210-G20		2.0(0.079)	R2		360	410	320(12.60)		
R-210-G25	2.5(0.098)	W2	360	510	330(13)				
R-210-S15	Suction	1.5(0.051)	K1	2.5-3.0 (0.24-0.29)	200	240	210(8.27)	536 (1.18)	Automobile and industry
R-210-S15		1.5(0.051)	K2		330	240	290(11.42)		
R-210-S18		1.8(0.071)	K2		330	290	340(13.39)		
R-210-S20		2.0(0.079)	R1		260	350	260(10.24)		
R-210-S20		2.0(0.079)	R2		300	350	290(11.42)		
R-210-S20		2.0(0.079)	R2		300	350	290(11.42)		
R-210-S25		2.5(0.098)	W2		300	440	280(11.02)		

◆R-210 Spraying distance: 250mm (9.84in). Fluid viscosity: 20±1 second/ RV-2. Coating pressure: 0.8kg/cm². Fluid and air inlet: 1/4 PF/NPF.

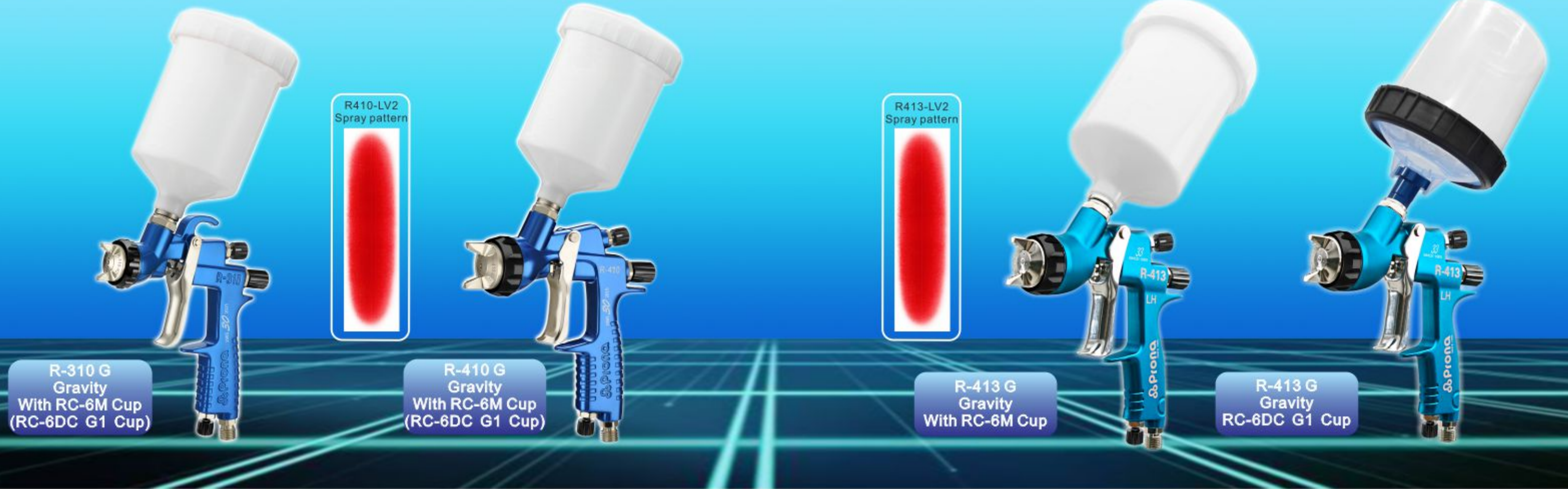

R-310 G Gravity With RC-6M Cup (RC-6DC G1 Cup)

R-410 G Gravity With RC-6M Cup (RC-6DC G1 Cup)

R-413 G Gravity With RC-6M Cup

R-413 G Gravity RC-6DC G1 Cup

Model	Type of feed	Nozzle size	Air cap	Air pressure	Air consumption	Fluid output	Spray width ±20	Weight	Use
		ømm (in)		kg/cm ² (Mpa)	l/min	ml/min	mm(in)	g(lbs)	
R-310-G10	Gravity	1.0(0.039)	E1	2.0-2.5 (0.2-0.24)	75	175	130(5.12)	425 (0.94)	Light industry
R-310-G10		1.0(0.039)	E2		145	150	200(7.87)		Automobile, furniture and industry
R-310-G13		1.3(0.051)	K1		145	280	170(6.69)		Woodwork, furniture and metalwork
R-310-G13		1.3(0.051)	H2		225	200	175(6.89)		Woodwork, furniture and industry
R-310-G13		1.3(0.051)	H4		210-250	200	205-220(8.07-8.66)		Woodwork, furniture and industry
R-310-G15		1.5(0.059)	K1		145	335	180(7.09)		Woodwork, furniture and metalwork
R-310-G15		1.5(0.059)	H2		225	235	190(7.48)		Woodwork, furniture and industry
R-310-G18		1.8(0.071)	N2		150	280	190(7.48)		Woodwork, furniture and metalwork
R-410-G12	Gravity	1.2(0.047)	LV2	2.0-3.0 (0.2-0.29)	320	160	230-250(9.06-9.84)	517 (1.14)	Automobile
R-410-G13		1.3(0.051)	LV2		320	180	240-260(9.45-10.24)		Automobile
R-410-G14		1.4(0.055)	LV2		320	215	250-275(9.84-10.82)		Automobile, furniture and industry
R-410-G15		1.5(0.059)	LV2		320	270	260-280(10.24-11.02)		Automobile
R-410-G16		1.6(0.063)	LV2		320	275	300-340(11.81-13.39)		Automobile, furniture and industry
R-410-G18		1.8(0.071)	LV2		320	330	330-335(12.99-13.98)		Automobile, furniture and industry
R-410-G20		2.0(0.079)	R2		360	410	320(12.60)		Middle viscosity painting, metalwork and woodwork
R-410-G25		2.5(0.098)	W1		360	580	340(13.39)		Bast coat, high viscosity painting
R-410-G25		2.5(0.098)	W2		360	510	320(12.60)		High viscosity painting, metalwork and woodwork.

◆R-310 Spraying distance: 200mm (7.87in). Fluid viscosity: 20±1 second/ RV-2. Fluid inlet: M16X1.5P. Air inlet: 1/4 PF/NPF.
 ◆R-410 Spraying distance: 250mm (9.84in). Fluid viscosity: 20±1 second/ RV-2. Fluid inlet: M16X1.5P. Air inlet: 1/4 PF/NPF.

Functions and Characteristics

- ◆Light weight forged aluminium gun body provides better control of operation. Anodizing and sand blasting surface is easy to clean and maintain.
- ◆Provide finer atomization and homogeneous spray pattern, reduce over spray perfectly in low air pressure.
- ◆The knob design provides easy adjustment.
- ◆Fluid liner inside the fluid cup supports better atomization and steable performance .
- ◆Nozzle and needle are made of stainless steel, suitable for water-based paints.

Model	Type of feed	Nozzle size	Air cap	Air pressure	Air consumption	Fluid output	Spray width ±20	Weight	Use
		ømm (in)		kg/cm ² (Mpa)	l/min	ml/min	mm(in)	g(lbs)	
R-413-G12	Gravity	1.2(0.047)	LV2	2.0-3.0 (0.2-0.29)	320	160	230-250(9.06-9.84)	464 (1.02)	Automobile
R-413-G13		1.3(0.051)	LV2		320	180	240-260(9.45-10.24)		Automobile
R-413-G14		1.4(0.055)	LV2		320	215	250-275(9.84-10.82)		Automobile, furniture and industry
R-413-G15		1.5(0.059)	LV2		320	270	260-280(10.24-11.02)		Automobile
R-413-G16		1.6(0.063)	LV2		320	275	300-340(11.81-13.39)		Automobile, furniture and industry
R-413-G18		1.8(0.071)	LV2		320	330	330-335(12.99-13.98)		Automobile, furniture and industry
R-413-G20		2.0(0.079)	R2		360	410	320(12.60)		Middle viscosity painting, metalwork and woodwork
R-413-G25		2.5(0.098)	W1		360	580	340(13.39)		Bast coat, high viscosity painting
R-413-G25		2.5(0.098)	W2		360	510	320(12.60)		High viscosity painting, metalwork and woodwork.

◆R-413 Spraying distance: 250mm (9.84in). Fluid viscosity: 20±1 second/ RV-2. Fluid inlet: M16X1.5P. Air inlet: 1/4 PF/NPF.



R-410-IP
Add Indirect pressure
Pressure
With RC-6MP cup



R-410-DP
Add direct pressure
Pressure
With RC-6MP cup

Functions and Characteristics

- ◆ This is a gravity feed spray gun with pressurized cup, the internal cup pressure can be control by adjusting the throttle valve. Suitable for high viscosity paint, can spray higher fluid spraying volume, improve efficiency.
- ◆ Provide better atomization and adhesion.
- ◆ R410-IP fill pressure type: when spraying pressure increase by filling air from spray gun to fluid cup, internal pressure can be adjust by the throttle valve on the gun body. When spray gun is not in use, no air will be supply to the fluid cup. During the operation of spray gun, **the internal cup pressure can not exceed 2kg/cm².**
- ◆ R410-DP steady pressure type: pressure increase by filling air from external to fluid cup, internal cup pressure can be adjust by the throttle valve on relief valve. the air will be continually supply to the fluid cup in order to stablized the pressure. When spray gun is not in use, the throttle valve shoule be turn off, then release the pressure. During the operation of spray gun, **the internal cup pressure can not exceed 2kg/cm².**
- ◆ Fluid liner inside the fluid cup supports better atomization and steable performance.
- ◆ Nozzle and needle are made of stainless steel, suitable for water-based paints.

Model	Type of feed	Nozzle size	Air cap	Air pressure	Air consumption	Fluid output	Spray width ±20	Weight	Use	
		ømm (in)		kg/cm ² (Mpa)	l/min	ml/min	mm(in)	g (lbs)		
R-410-IP-P12	Gravity	1.2(0.047)	LV2	2.0-3.0 (0.2-0.29)	320	160	230-250(9.06-9.84)	517 (1.14)	Automobile	
R-410-IP-P13		1.3(0.051)	LV2							240-260(9.45-10.24)
R-410-IP-P14		1.4(0.055)	LV2							250-275(9.84-10.82)
R-410-IP-P15		1.5(0.059)	LV2							260-280(10.24-11.02)
R-410-IP-P16		1.6(0.063)	LV2							300-340(11.81-13.39)
R-410-IP-P18		1.8(0.071)	LV2							330-355(12.99-13.98)
R-410-IP-P20		2.0(0.079)	R2							320(12.60)
R-410-IP-P25		2.5(0.098)	W1							340(13.39)
R-410-IP-P25	2.5(0.098)	W2	320(12.60)	High viscosity painting, metalwork and woodwork.						
R-410-DP-P12	Gravity	1.2(0.047)	LV2	2.0-3.0 (0.2-0.29)	320	160	230-250(9.06-9.84)	517 (1.14)	Automobile	
R-410-DP-P13		1.3(0.051)	LV2							240-260(9.45-10.24)
R-410-DP-P14		1.4(0.055)	LV2							250-275(9.84-10.82)
R-410-DP-P15		1.5(0.059)	LV2							260-280(10.24-11.02)
R-410-DP-P16		1.6(0.063)	LV2							300-340(11.81-13.39)
R-410-DP-P18		1.8(0.071)	LV2							330-355(12.99-13.98)
R-410-DP-P20		2.0(0.079)	R2							320(12.60)
R-410-DP-P25		2.5(0.098)	W1							340(13.39)
R-410-DP-P25	2.5(0.098)	W2	320(12.60)	High viscosity painting, metalwork and woodwork.						

◆R-410-IP Spraying distance: 250mm (9.84in). Fluid viscosity: 20±1 second/ RV-2. Fluid inlet: M16X1.5P. Air inlet: 1/4 PF/NPF.
 ◆R-410-DP Spraying distance: 250mm (9.84in). Fluid viscosity: 20±1 second/ RV-2. Fluid inlet: M16X1.5P. Air inlet: 1/4 PF/NPF.



R-4300(S)-P
Pressure



R-4300(S)-S
Suction
With RC-1 CUP
(RC-6DC S1 Cup)

Functions and Characteristics

- ◆ Provide fine atomization, stable fluid spraying volume and excellent adhesion , less over spray,
- ◆ This spray gun is specifically designed for spraying water-based paints, perfect for the application of clear coat, base and metallic materials in automotive industries.
- ◆ Stainless steel fluid needle, nozzle and fluid connector are abrasion and corrosion resistant.
- ◆ Spray gun cups are available in different types (reusable plastic/aluminium cup or disposable cup)and various sizes. When the there is a need of using disposable cup, just add a RFC-TG1 adaptor.
- ◆ **R-4300-S/P the fluid passage is made of aluminium alloy.**
- ◆ **R-4300S-S/P the fluid passage is made of stainless steel.**

Model	Type of feed	Nozzle size	Air cap	Air pressure	Air consumption	Fluid output	Pattern width±20	Weight
		Ømm(in)		kg/cm ² (Mpa)	l/min	ml/min	mm(in)	g(lbs)
R-4300(S)-S13	Pressure	1.3(0.051)	MP	2.0-2.5 (0.2-0.24)	360	180	170(6.69)	522 (1.15)
R-4300(S)-S14		1.4(0.055)				185	180(7.09)	
R-4300(S)-S15		1.5(0.059)				190	210(8.27)	
R-4300(S)-S18		1.8(0.070)				200	220(8.66)	
R-4300(S)-P08	Suction	0.8(0.031)	MP	2.0-2.5 (0.2-0.24)	360	360	295(11.61)	
R-4300(S)-P11		1.1(0.043)				380	310(12.20)	
R-4300(S)-P12		1.2(0.047)				400	320(12.60)	
R-4300(S)-P13		1.3(0.051)				410	330(12.00)	
R-4300(S)-P14		1.4(0.055)				418	338(13.30)	
R-4300(S)-P15		1.5(0.059)				430	350(13.78)	
R-4300(S)-P18		1.8(0.070)				462	382(15.04)	
R-4300(S)-P20		2.0(0.079)				480	390(15.35)	
R-4300(S)-P22		2.2(0.087)				500	405(15.94)	

◆R-4300(S) Spraying distance: 200-250mm (7.87-9.84in). Fluid viscosity: 20±1 second/ RV-2. Fluid inlet: 3/8PF/NPF. Air inlet: 1/4 PF/NPF.



Functions and Characteristics

- ◆ Providing fine atomization, stable fluid spraying volume and excellent adhesion, less over spray,
- ◆ This spray gun is specifically designed for spraying water-based paints, perfect for the application of clear coat, base and metallic materials in automotive industries.
- ◆ Stainless steel fluid needle, nozzle and fluid connector are abrasion and corrosion resistant.
- ◆ Spray gun cups are available in different types (reusable plastic/aluminium cup or disposable cup) and various sizes. Use RFC-TG1 adaptor when disposable cup is applied.

Model	Type of feed	Nozzle size	Air cap	Air pressure	Air consumption	Fluid output	Spray width ±20	Weight				
		ømm (in)		kg/cm ² (Mpa)	l/min	ml/min	mm(in)	g(lbs)				
R-4300/4303-MP-G08	Gravity	0.8(0.031)	MP	2.0-2.5 (0.2-0.24)	340	290	200-320 (7.87-12.60)	R-4300: 525(1.16) R-4303: 481(1.06)				
R-4300/4303-MP-G11		1.1(0.043)				340						
R-4300/4303-MP-G12		1.2(0.047)				350						
R-4300/4303-MP-G13		1.3(0.051)				360						
R-4300/4303-MP-G14		1.4(0.055)				370						
R-4300/4303-MP-G15		1.5(0.059)				400						
R-4300/4303-MP-G18		1.8(0.071)				435						
R-4300/4303-HVLP-G08		0.8(0.031)				HVLP			2.0(0.2)	430	200	190-300 (7.48-11.81)
R-4300/4303-HVLP-G11		1.1(0.043)									240	
R-4300/4303-HVLP-G12		1.2(0.047)	250									
R-4300/4303-HVLP-G13		1.3(0.051)	270									
R-4300/4303-HVLP-G14		1.4(0.055)	280									
R-4300/4303-HVLP-G15		1.5(0.059)	300									
R-4300/4303-HVLP-G18		1.8(0.071)	335									

◆R-4300/R-4303 Spraying distance: 200mm (7.87in). Fluid viscosity: 20±1 second/ RV-2. Fluid inlet: M16X1.5P. Air inlet: 1/4 PF/NPF.

Model	Type of feed	Nozzle size	Air cap	Air pressure	Air consumption	Fluid output	Spray width ±20	Weight		
		ømm (in)		kg/cm ² (Mpa)	l/min	ml/min	mm(in)	g(lbs)		
R-4600-MP-G11	Gravity	1.1(0.043)	MP	2.0-2.5 (0.2-0.24)	340	320	260(10.24)	519(1.14)		
R-4600-MP-G12		1.2(0.047)				330				
R-4600-MP-G13		1.3(0.051)				340				
R-4600-MP-G14		1.4(0.055)				350				
R-4600-MP-G15		1.5(0.056)				360				
R-4600-MP-G17		1.7(0.067)				370				
R-4600-HVLP-G11		1.1(0.043)				HVLP			2.0(0.2)	430
R-4600-HVLP-G12		1.2(0.047)	240							
R-4600-HVLP-G13		1.3(0.051)	250							
R-4600-HVLP-G14		1.4(0.055)	260							
R-4600-HVLP-G15		1.5(0.059)	280							
R-4600-HVLP-G17		1.7(0.067)	300							
R-430-G11		Gravity	1.1(0.043)	HVLP	2.0(0.2)		360			
R-430-G12			1.2(0.047)			240				
R-430-G13			1.3(0.051)			250				
R-430-G14			1.4(0.055)			258				

◆R-4600 Spraying distance: 200mm (7.87in). Fluid viscosity: 20±1 second/ RV-2. Fluid inlet: M16X1.5P. Air inlet: 1/4 PF/NPF.
 ◆R-430 Spraying distance: 200mm (7.87in). Fluid viscosity: 20±1 second/ RV-2. Fluid inlet: M16X1.5P. Air inlet: 1/4 PF/NPF.



RL-403 G
Gravity
With RC-6M CUP
(RC-6DC G1 Cup)

RL-101 P
Pressure

RL-100 P
Pressure



RL-103 P
Pressure

RL-200 P
Pressure

RL-203 P
Pressure

Functions and Characteristics

- ◆ Lightweight gun body makes working with this spray gun very easy and the trigger provide a much smoother and more comfortable trigger pull.
- ◆ Air pressure at the air cap is lower than 0.7 bar, provide excellent adhesion and wider spray pattern, suitable for spraying metallic paints.
- ◆ Paint consumption can be reduced by about 20-30%.
- ◆ Featuring stainless steel fluid passages for waterborne compatibility.
- ◆ Heat-treated stainless steel fluid needle and nozzle are corrosion resistant, more durable and provide longer service life.

Model	Type of feed	Nozzle size	Air cap	Air pressure	Air consumption	Fluid output	Spray width ±20	Weight	Use
		ømm (in)		kg/cm ² (Mpa)	l/min	ml/min	mm(in)	g(lbs)	
RL-403-G12	Gravity	1.2(0.047)	J2	2.0-3.0 (0.2-0.29)	280-370	140	260(10.24)	507 (1.12)	Metalwork, woodwork, resin spraying
RL-403-G14		1.4(0.055)	J2		280-370	180	290(11.42)		
RL-403-G16		1.6(0.063)	J2		280-370	205	310(12.20)		
RL-101-P08	Pressure	0.8(0.031)	E1	2.0-2.5 (0.2-0.24)	430	140	200 (8.78)	397 (0.88)	Metalwork, woodwork, resin spraying
RL-101-P10		1.0(0.039)	E1		430	150			
RL-101-P12		1.2(0.047)	G2		530	300			
RL-100-P08	Pressure	0.8(0.031)	E1	2.0-2.5 (0.2-0.24)	430	140	200 (8.78)	397 (0.88)	Metalwork, woodwork, resin spraying
RL-100-P10		1.0(0.039)	E1		430	150			
RL-100-P12		1.2(0.047)	G2		530	300			

- ◆RL-403 Spraying distance: 200mm (7.87in). Fluid viscosity: 20±1 second/RV-2. Fluid inlet:M16X1. Air inlet: 1/4 PF/NPF.
- ◆RL-101 Spraying distance: 200mm (7.87in). Fluid viscosity: 20±1 second/RV-2. Operating pressure: 0.8kg/cm². Fluid and air inlet: 1/4 PF/NPF.
- ◆RL-100 Spraying distance: 200mm (7.87in). Fluid viscosity: 20±1 second/RV-2. Operating pressure: 0.8kg/cm². Fluid and air inlet: 1/4 PF/NPF.

Functions and Characteristics

- ◆ Lightweight gun body makes working with this spray gun very easy and the trigger provide a much smoother and more comfortable trigger pull.
- ◆ Air pressure at the air cap is lower than 0.7 bar, provide excellent adhesion and wider spray pattern, suitable for spraying metallic paints.
- ◆ Paint consumption can be reduced by about 20-30%.
- ◆ Featuring stainless steel fluid passages for waterborne compatibility.
- ◆ Heat-treated stainless steel fluid needle and nozzle are corrosion resistant, more durable and provide longer service life.

Model	Type of feed	Nozzle size	Air cap	Air pressure	Air consumption	Fluid output	Spray width ±20	Weight	Use
		ømm (in)		kg/cm ² (Mpa)	l/min	ml/min	mm(in)	g(lbs)	
RL-103-P08	Pressure	0.8(0.031)	E1	2.0-2.5 (0.2-0.24)	430	140	200 (8.87)	423 (0.93)	Metalwork, woodwork, resin spraying
RL-103-P10		1.0(0.039)	E1			150			
RL-103-P12		1.2(0.047)	G2			300			
RL-200-P08	Pressure	0.8(0.031)	G2	2.0-2.5 (0.2-0.24)	500	400	300 (11.81)	493 (1.09)	Metalwork, woodwork, resin spraying
RL-200-P10		1.0(0.039)	G2			400			
RL-200-P12		1.2(0.047)	G2			500			
RL-203-P08	Pressure	0.8(0.031)	G2	2.0-2.5 (0.2-0.24)	500	400	300 (11.81)	529 (1.17)	Metalwork, woodwork, resin spraying
RL-203-P10		1.0(0.039)	G2			400			
RL-203-P12		1.2(0.047)	G2			500			

- ◆RL-103 Spraying distance: 200mm (7.87in). Fluid viscosity: 20±1 second/RV-2. Operating pressure: 0.8kg/cm². Fluid and air inlet: 1/4 PF/NPF.
- ◆RL-200 Spraying distance: 200mm (7.87in). Fluid viscosity: 20±1 second/RV-2. Operating pressure: 0.8kg/cm². Fluid inlet: 3/8 PF/NPF. Air inlet: 1/4 PF/NPF.
- ◆RL-203 Spraying distance: 200mm (7.87in). Fluid viscosity: 20±1 second/RV-2. Operating pressure: 0.8kg/cm². Fluid inlet: 3/8 PF/NPF. Air inlet: 1/4 PF/NPF.



R-77-Z(ZP)
Suction
With RC-1Cup

R-200-Z(ZP)
Pressure

RA-200-Z(ZP)
Pressure

Functions and Characteristics

- ◆ Both needle and nozzle are made of special treated stainless steel which is treated specially.
- ◆ Suitable for spraying water-based ceramic enamel or easy-wear coating material.
- ◆ Z: Nozzle is made of black nitride treated material. ZP: Nozzle is made of stainless steel.

Model	Type of feed	Nozzle size	Air cap	Air pressure	Air consumption	Fluid output	Spray width ±20	Weight
		mm(in)		kg/cm ² (Mpa)	l/min	ml/min	mm(in)	g(lbs)
R-77--Z(ZP)20	Suction	2.0(0.079)	-	3.5(0.34)	293	370	280(11.02)	590(1.3)
R-77--Z(ZP)25		2.5(0.098)			300	660	380(14.89)	
R-77--Z(ZP)30		3.0(0.118)			329	699	440(17.32)	
R-200-201-Z(ZP)	Pressure	2.0(0.079)	R1Z	3.5(0.34)	500	760	370(14.57)	503(1.10)
R-200-251-Z(ZP)		2.5(0.098)			500	760	370(14.57)	
RA-200-201-Z(ZP)	Pressure	2.0(0.079)	R1Z	3.5(0.34)	500	760	370(14.57)	550(1.21)
RA-200-251-Z(ZP)		2.5(0.098)			500	760	370(14.57)	

- ◆ R-77-Z(ZP) Spraying distance: 250mm (9.84in). Fluid inlet: 3/8 PF/NPF. Air inlet: 1/4 PF/NPF.
- ◆ R-200-Z(ZP) Spraying distance: 250mm (9.84in). Fluid inlet: 3/8 PF/NPF. Air inlet: 1/4 PF/NPF.
- ◆ RA-200-Z(ZP) Spraying distance: 250mm (9.84in). Fluid inlet: 3/8 PF/NPF. Air and CYL: 1/4 PF/NPF.

Spray pattern



Functions and Characteristics

- ◆ The water in water multicolor paint spray gun can be used in coating factory for interior and exterior wall painting. Suitable for latex paint, metallic paint, fluorocarbon paint, multicolor paint faux finishing paint and stone paint.
- ◆ SGD-R77 provide even atomization and produce a nice stone-like effect.
- ◆ This spray gun has the advantages of stable and reliable working performance,
- ◆ Different nozzle sizes are available.
- ◆ SGD-R77 Fluid inlet: 3/8 PF/NPF, air inlet: 1/4 PF/NPF.



SGD-R77
Pressure

Model	Type of feed	Nozzle size	Air pressure	Air consumption	Fluid output	Weight
		mm (in)	kg/cm ² (Mpa)	l/min	ml/min	g(lbs)
SGD-R77	Pressure	1.2(0.047)	1.0-3.5 (0.1-0.34)	560	380	540 (1.19)
		1.5(0.059)			400	
		2.0(0.079)			440	
		2.5(0.098)			480	
		3.0(0.118)			520	

Circuit diagram

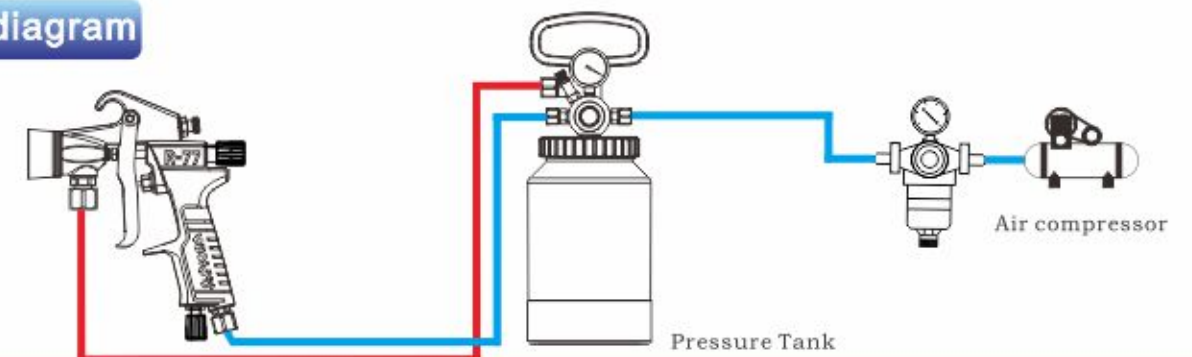

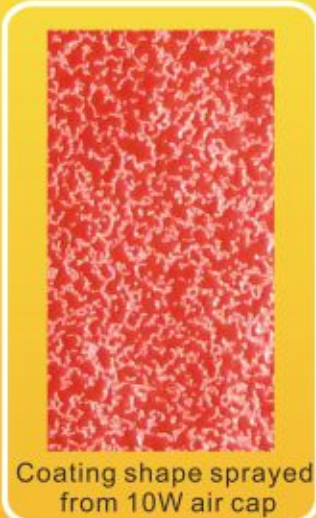

Coating shape sprayed from 10W air cap

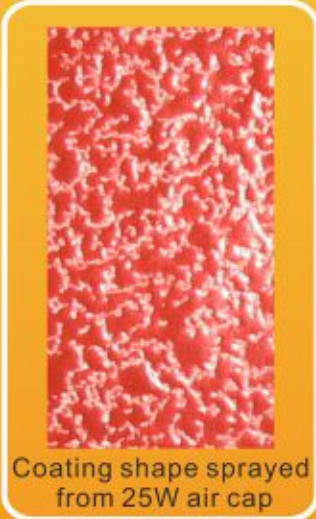

Coating shape sprayed from 25W air cap



R-871 Pressure With RC-19B



R-2003 Pressure With RC-19B



Spattering or Specking



Misting or Shading

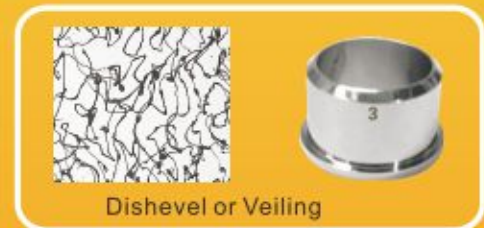

Dishevel or Veiling

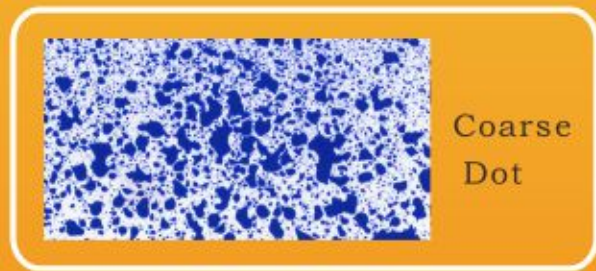

Coarse Dot



SGD-71 Pressure With RC-17R Cup



SGD-RA200 Pressure



SGD-RA100 Pressure

Functions and Characteristics

- ◆ R-2300 is suitable for spraying large area with high viscosity paint; can be used in shoes industries and furniture decoration etc.
- ◆ R-871 is suitable for wall painting(multi-color paint), superglue and plaseter.

Model	Type of feed	Nozzle size	Air cap	Air pressure	Air consumption	Fluid output	Spray width ±20	Weight
		ømm (in)		kg/cm ² (Mpa)	l/min	ml/min	mm(in)	g(lbs)
R-2003-P20	Pressure	2.0(0.079)	R2	3.0(0.29)	260	350	290(11.42)	480(1.06)
R-2003-P25		2.5(0.098)	W2		360	440	300(11.81)	
R-871-10W	Pressure	2.5(0.098)	10W	3.0-4.0(0.29-0.39)	140	440	100-250(3.94-9.84)	505(1.13)
R-871-25W		2.5(0.098)	25W					

- ◆ R-2003 Spraying distance: 250mm (7.8mm). Fluid inlet: M16 X 1.5P. Air inlet: 1/4 PF/NPF.
- ◆ R-871 Spraying distance: 200 - 300mm (7.87 - 11.81in). Fluid inlet: M16 x 1.5 P. Air inlet: 1/4 PF/NPF.

Functions and Characteristics

- ◆ SGD-RA100 can produce three different pattern: spattering, misting and dishevel, suitable to use in appearance decoration.
- ◆ For spattering pattern: use cap #1, Fluid viscosity: 20 second/RV-2, fluid pressure: 0.3kg/cm² and air pressure: 0.5 - 0.7 kg/cm².
- ◆ For misting pattern, use cap#2. Fluid viscosity: 25 second/RV-2, fluid pressure: 0.3kg/cm² and air pressure: 0.5 - 0.7 kg/cm².
- ◆ For dishevel pattern, use cap#3. Fluid viscosity: 55 second/RV-2, fluid pressure: 0.3kg/cm² and air pressure: 0.5 - 0.7 kg/cm².
- ◆ Data shown above is for reference only, please adjust according to fluid quality and performance.
- ◆ SGD-71/SGD-RA100 Fluid and air inlet: 1/4 PF/NPF. SGD-200 Air inlet: 1/4 PF/NPF, fluid inlet: 3/8 PF/NPF.

Model	Type of feed	Nozzle size	Air pressure	Air consumption	Fluid output	Weight
		ømm (in)	kg/cm ² (Mpa)	l/min	ml/min	g(lbs)
SGD-71	Pressure	0.7(0.028)	1.0-2.5(0.1-0.25)	80	80	1042(2.3)
		2.0(0.079)		140	240	
SGD-RA200	Pressure	0.7(0.028)	1.0-2.5(0.1-0.25)	80	80	495(1.09)
		2.0(0.079)		140	240	
SGD-RA100	Pressure	0.8(0.031)	1.0-2.5(0.1-0.25)	80	80	505(1.11)



Name: Draw pump
 Power: 95W
 Frequency: 50Hz/60Hz
 The
 Maximum: 40psi
 Length: 250mm
 (9.84in)
 Weight: 3.85kg
 (8.49lbs)



Functions and Characteristics

- ◆ Suitable for small area sparying.
- ◆ Ideal for : fine art, nail art, tattoos and more.

Model	Type of feed	Standard color container	Nozzle size	Air pressure	Air consumption	Fluid output	Weight
		ml	ømm (in)	kg/cm ² (Mpa)	l/min	ml/min	g(lbs)
RH-A	Gravity	0.2	0.2(0.008)	1.0-3.0 (0.1-0.29)	11	12	84(0.185)
RH-B	Gravity	3	0.2(0.008)		11		87(0.19)
RH-C	Gravity	7	0.3(0.012)		14		87(0.19)
RH-BS	Suction	30	0.3-0.5(0.012-0.020)		14-16		104(0.23)
RH-AP	Gravity	0.2	0.2(0.008)		11		84(0.185)
RH-BP	Gravity	3	0.2(0.008)		11		87(0.19)
RH-CP	Gravity	7	0.3(0.012)		14		90(0.20)
RH-RAP	Gravity	7	0.3(0.012)		14		90(0.20)
RH-GP	Gravity	7-15	0.35(0.014)		15		104(0.23)
RH-GP2	Gravity	2-7	0.3(0.012)		14		104(0.23)
RH-L100	Gravity	2-7	0.3(0.012)		14		90(0.20)

Artistic air brush



Model	Type of feed	Nozzle size	Air cap	Air pressure	Air consumption	Fluid output	Spray width ±20	Weight
		ømm (in)		kg/cm ² (Mpa)	l/min	ml/min	mm(in)	g(lbs)
RH-80R	Gravity	0.3(0.012)	03R	0.8-2.0 (0.08-0.2)	10	8	5(0.2)	220(0.49)
RH-80F	Gravity	0.3(0.012)	03F	0.8-2.0 (0.08-0.2)	15	12	35(1.38)	225(0.5)
RH-90R	Gravity	0.3(0.012)	03R		10	8	5(0.2)	329(0.73)
RH-90F	Gravity	0.3(0.012)	03F	15	12	35(1.38)	336(0.74)	

- ◆ RH-80 R/F - Spray distance: 100-150mm (3.9 - 5.9 in). Fluid and air inlet: 1/4 PF/NPF.
- ◆ RH-90 R/F - Spray distance: 100-150mm (3.9 - 5.9 in). Fluid inlet: M8X 1.0P, air inlet: 1.4 PF/NPF.

Air duster gun



Functions and Characteristics

- ◆ Suitable for small pieces body color painting , imitated tattoo, artwork, etc.
- ◆ Air connector: RG-7 1/4PF. Speedy connector: RG-7 Q.

Model	Air cap	Nozzle size	Air pressure	Air consumption	Weight
		ømm(in)	kg/cm ² (Mpa)	l/min	g(lbs)
RG-7-1#(Q)	Short	2.0(0.08)	3.5(0.34)	145	215(0.47)
RG-7-4#(Q)	100/280 mm			320	
RG-7-J#(Q)	Regulable			0-145	



Paint pressurized tank
Application NO:201820637833.2

Functions and Characteristics

- ◆ Pressure tank is manufactured by integrated molding of pressure resistant steel plate. Its surface received special antirust treatment, provide high safety.
- Fluid feed can be siphoned form the top - suitable for normal fluid or drand at the bottom of the tank - suitable for high viscosity fluid. (subject to the size of the tank).
- ◆ The pressure tank can be classified into three types: with agitator, with manual agitator and pressure pot only.
- ◆ The pressure tank also equipped with an fluid liner bucket, which is made by SUS304 stainless steel (subject to the size of the tank).
- ◆ **Warning: Do not operate the pressure tank exceed the maximum pressure. Prona Tools Inc will not hold any responsibility in case of accidents occur due to improper use of product.**



Moving wheel seat set type
paint pressurized tank
Application NO:201520046566.8

1. The pressure tank equipped with three swivel casters.
2. The casters can be hidden at the bottom of the pressure tank.

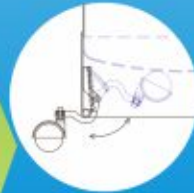

Functional specification of automotive pressure tank

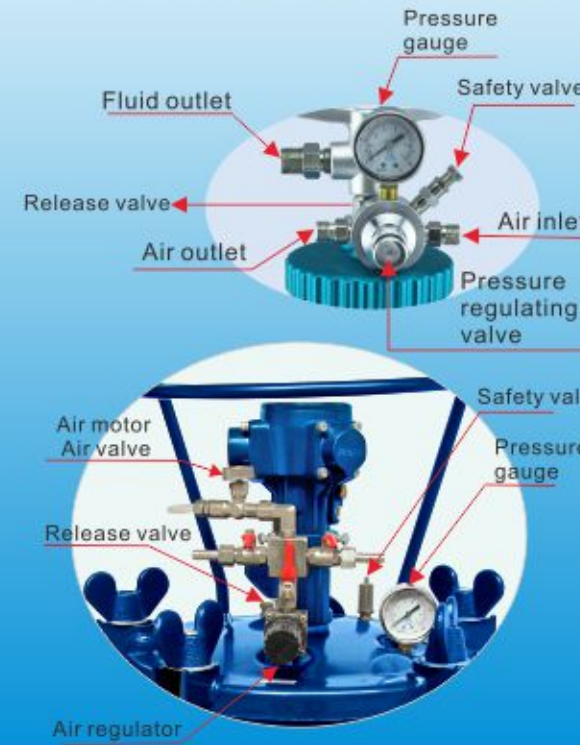

Small Pressure Tank



Functions and Characteristics

- ◆ The fluid liner bucket of RT-5E is made of SUS stainless steel.
- ◆ RC-2E and RT-2E areby integrated molding of aluminum-alloy with anodixe process on the surface, provide high safety performance.
- ◆ It is light weight and portable.
- ◆ **Warning: No to operat the pressure tank exceed the maximum pressure (0.3 Mpa). Prona Tools Inc will not hold any responsibility in case of accidents occur due to improper use of product.**
- ◆ **Do not use aluminum-corrosion material.**

Model	Use	Capacity (L)	Pressure (Mpa(kgf/cm ²))	Operation	Fluid outlet	Fluid liner bucket size (Ømmxmm(Øinxin))	Net weight (kg(lbs))	Gross weight (kg(lbs))
RT-2E	Small Amount Spray	2	0.3(3.0)	Economy (None Agitator)	1/4x1	129.5x199(5.1x7.83)	1.52(3.35)	1.64(3.62)
RC-2E		2	0.3(3.0)	Economy (None Agitator)	3/8x1	129.5x199(5.1x7.83)	1.54(3.4)	1.67(3.56)
RT-5M		5	0.3(3.0)	Manual	1/4x1	180x204(7.09x8.031)	6.6(14.55)	7.5(16.53)
RT-5A		5	0.3(3.0)	Automatic	1/4x1	180x204(7.09x8.031)	7(15.43)	7.7(16.98)
RT-5AS		5	0.3(3.0)	Automatic (stainless)	1/4X1	180x204(7.09x8.031)	7.7(16.98)	8.7(16.1)
RT-5E		5	0.3(3.0)	Economy (None Agitator)	1/4x1	180x204(7.09x8.031)	6.3(13.89)	7.0(15.43)
RT-5ES		5	0.3(3.0)	Economy (None Agitator)	1/4X1	180X204(7.09X8.031)	6.7(14.77)	7.7(16.98)

Model	Use	Capacity (L)	Pressure (Mpa(kgf/cm ²))	Operation	Fluid outlet	Fluid liner bucket size (Ømmxmm(Øinxin))	Net weight (kg(lbs))	Gross weight (kg(lbs))
RT-10M	Mass Amount Spray	10	0.3(3.0)	Manual	1/4x1	248x185(9.76x7.28)	16(35.27)	17.5(38.58)
RT-20M		20	0.3(3.0)		1/4x2	292x365(11.5x14.37)	21.2(46.74)	23.8(52.47)
RT-40M		40	0.19(1.9)		1/4x2	350x395(13.78x15.55)	28.3(62.39)	31.9(70.33)
RT-60M		60	0.19(1.9)		1/4x2	350x548(13.78x21.57)	33.8(74.5)	38(83.77)
RT-10A	Mass Amount Spray	10	0.3(3.0)	Automatic	1/4x1	248x185(9.76x7.28)	17.7(39)	19.3(42.55)
RT-20A		20	0.3(3.0)		1/4x2	292x365(11.5x14.37)	22.9(50.5)	25.5(56.22)
RT-40A		40	0.19(1.9)		1/4x2	350x395(13.78x21.57)	30(66.14)	33.6(74.07)
RT-60A		60	0.19(1.9)		1/4x2	350x548(13.78x21.56)	35.4(78)	39.8(87.74)
RT-10AS	Mass Amount Spray (stainless)	10	0.3(3.0)	Automatic	1/4x1	248x185(9.76x7.28)	18.3(40.34)	19.9(43.87)
RT-20AS		20	0.3(3.0)		1/4x2	292x365(11.5x14.37)	23.7(52.25)	26.3(58)
RT-40AS		40	0.19(1.9)		1/4x2	350x395(13.78x15.55)	31.3(69)	34.9(76.94)
RT-10AFG	Mass Amount Spray (Lower)	10	0.3(3.0)	Automatic	1/2x1	248x185(9.76x7.28)	17.7(39)	19.3(42.55)
RT-20AFG		20	0.3(3.0)		1/2x1	292x365(11.5x14.37)	22.9(50.5)	25.5(56.22)
RT-40AFG		40	0.19(1.9)		1/2x1	350x395(13.78x15.55)	30(66.14)	33.6(74.07)
RT-10E	Mass Amount Spray	10	0.3(3.0)	Economy (None Agitator)	1/4x1	248x185(9.76x7.28)	15.9(35.1)	17.4(38.36)
RT-20E		20	0.3(3.0)		1/4x2	292x365(11.5x14.37)	21.1(46.5)	23.7(52.25)
RT-40E		40	0.19(1.9)		1/4x2	350x395(13.78x15.55)	30(66.14)	33.6(74.07)
RT-60E		60	0.19(1.9)		1/4x2	350x548(13.78x21.57)	33.8(74.5)	39.8(87.74)
RT-20EFG	Mass Amount Spray (Lower)	20	0.3(3.0)	Economy (None Agitator)	1/2x1	292x356(11.5x14.37)	21.1(46.5)	23.7(52.25)
RT-40EFG		40	0.19(1.9)		1/2x1	350x395(13.78x15.55)	30(66.14)	33.6(74.07)
RT-60EFG		60	0.19(1.9)		1/2x1	350x548(13.78x21.57)	33.8(74.5)	39.8(87.74)

Stainless steel bucket lid with agitator

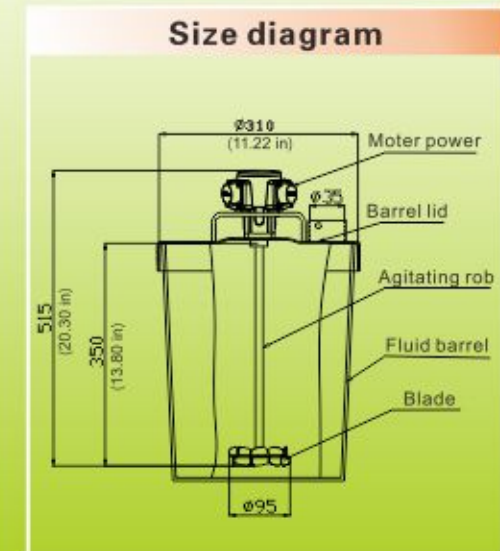

Air Motor	M10	M30
Motor power	1/16HP	1/4HP
Capacity	20(L)	
Blade size	Ø95mm (3.74 in)	
Axes size	Ø12x350mm (0.47x13.78 in)	
Dimension	380x350x225mm (14.96x13.78x8.86 in)	
Weight	5.1kg (11.24 lbs)	
Material	Stainless steel	



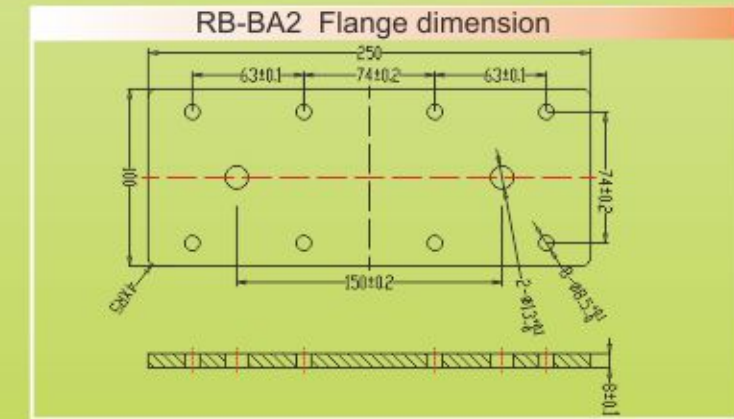
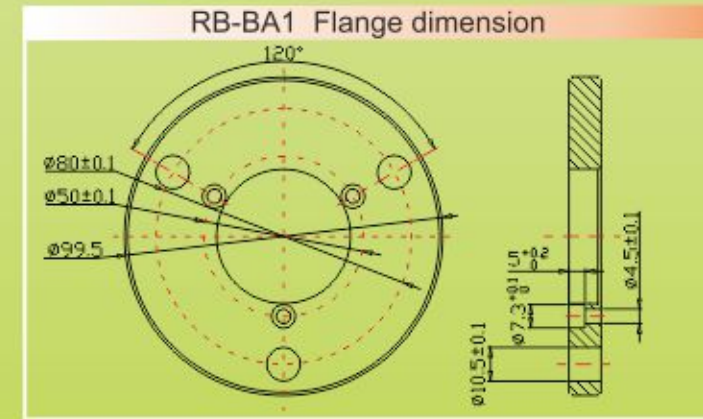
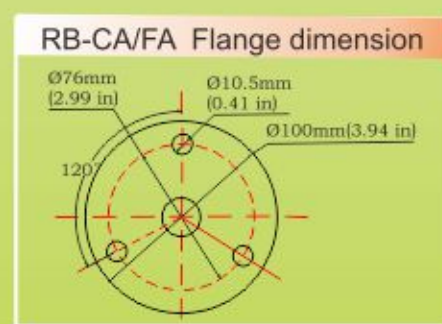
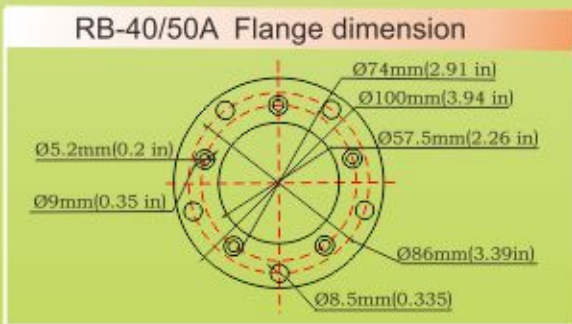

Model	Name	Air motor	Horse power		Capacity	Axis size	Axis dimension	Carton box size	Weight
			HP	KW					
RB-40A	Mini type agitator with housing	M40	2/5	0.3	200	160(6.30)	15x800(0.59x31.50)	1140x180x180(44.87x7x7)	7(15.43)
RB-50A	Mini type agitator with housing	M50	1/2	0.37	200	160(6.30)	15x800(0.59x31.50)	1140x180x180(44.87x7x7)	7(15.43)
RB-MA2	Hand hold type agitator	M40	2/5	0.3	200	160(6.30)	15x800(0.59x31.50)	1140x180x180(44.87x7x7)	7(15.43)
RB-CA	Clamp Type Agitator	M30	1/4	0.19	200	160(6.30)	15x800(0.59x31.50)	1140x180x180(44.87x7x7)	6.8(15)
RB-FA	Mini type agitator with housing	M30	1/4	0.19	200	160(6.30)	15x800(0.59x31.50)	1140x180x180(44.87x7x7)	4.3(9.48)
RB-2A	Pressure Tank Agitator	M30	1/4	0.19	20	95(3.74)	12x350(0.17x13.78)	1140x180x180(44.87x7x7)	2.7(5.95)
RB-4A	Pressure Tank Agitator	M30	1/4	0.19	40	95(3.74)	12x400(0.17x15.75)	1140x180x180(44.87x7x7)	2.74(6.05)
RB-6A	Pressure Tank Agitator	M30	1/4	0.19	60	95(3.74)	12x550(0.17x21.65)	1140x180x180(44.87x7x7)	2.83(6.24)
RB-MA	Hand hold type agitator	M30	1/4	0.19	20	95(3.74)	15x800(0.59x31.50)	1140x180x180(44.87x7x7)	3.1(6.83)
RB-MA1	Hand hold type agitator	M10	1/16	0.12	10	95(3.74)	12x350(0.17x13.78)	480x130x210(18.9x5.12x8.27)	1.15(2.54)
RB-MN	Mini type agitator	M10	1/16	0.12	10	95(3.74)	12x350(0.17x13.78)	480x130x210(18.9x5.12x8.27)	0.75(1.65)
RB-MN1	Mini type agitator with housing	M10	1/16	0.12	10	95(3.74)	12x350(0.17x13.78)	480x130x210(18.9x5.12x8.27)	1.3(2.71)

Model	Name	Air motor	Horse power		Capacity	Blade size	Axes size	Dimension	Weight
			HP	KW					
RB-LA	Elevation Type Agitator	M30	1/4	0.19	40	95(3.74)	12x350(0.17x13.78)	1140x180x180(44.87x7x7)	26.08(57.50)
RB-BA	Manual lift bench type agitator	M30	1/4	0.19	40	95(3.74)	12x350(0.17x13.78)	540x420x210(21.26x16.54x8.27)	17(3.47)
RB-BA1	Mini type agitator with housing	M30	1/4	0.19	40	95(3.74)	12x350(0.17x13.78)	480x130x210(18.9x5.12x8.27)	1.3(2.71)
RB-BA2	Mini type agitator with housing	M30	1/4	0.19	40	95(3.74)	12x660(0.17x25.98)	540x420x210(21.26x16.54x8.27)	8(17.64)
RB-SA	Four-leg stand type agitator	M30	1/4	0.19	20	95(3.74)	12x350(0.17x13.78)	385x355x485(15.16x14x19)	5.5(12.13)

RB-SA Suitable for maximum 290mm(11.4in) diameter tanks.
RB-CA Maximum distance of clamp is 1~25mm (0.04~0.1in)
RB-SA, RB-2/4/6A, RB-MA, RB-BA/BA1/BA2, RB-LA Suitable blade model: RMB-1B, RMB-1S, RMB-21AS.
RB-MN, RB-MN1, RB-MA1 Suitable blade model: RMB-1S, RMB-5AS.
RB-40A/50A, RB-MA2, RB-CA, RB-FA Suitable blade model: RMB-3B, RMB-CA, RMB-CS.
 (For more details of fluid agitator blade, please refer to page 74.)



Air-Powered Double Diaphragm Pumps

After years of research and development, Prona air-operated double-diaphragms are stable in quality and have mature technology, also have been recognized in ASIA, Europe, America and other countries. Suitable for all kinds of industries, such as atomized industries, furniture, aerospace, beverage, food, ceramics, chemical, construction, cosmetics, sewage, painting, plating, medical, package, boat-building, textile, carpet, electronics, wine-making, environmental, etc.

Double-diaphragm with fluid agitator

★ Details:
 R Series: Aluminium Alloy
 RS Series: Stainless Steel PP Series: Plastic
 Normal: Use USS Ceramic: Use OSO
 Casting industries: Use ONO Strong PH: Use OTO



RS-1500
RS-2600
Equipped with stabilizer

R-1500/R-2000
Equipped with stabilizer

R-1500-B
Equipped with stabilizer and agitator

R-1500-D2
R-2000-D2
Double in / outlet
Equipped with two stabilizer.

R-1500-S1
R-2000-S1
Double in / outlet
Equipped with stabilizer.

R-15/R-18 RS-15/RS-18 R-20/R-23 RS-20/RS-23 PP-20



Pneumatic double diaphragm pump
 Application NO:201420624159.6

Aluminum-Alloy Pump Series	R-15/RS-15/R-1500/R-1500-B	R-18/RS-18	R-20/RS-20	R-23/RS-23	PP-20
Fluid inlet	(3/8 inch)	(3/8 inch)	(1/2 inch)	(1/2 inch)	(1/2 inch)
Maximum pressure	7 bar	7 bar	7 bar	7 bar	7 bar
Fluid inlet	3/8"NPT	3/8"NPT	1/2"NPT	1/2"NPT	1/2"NPT
Air inlet	1/4"NPT	1/4"NPT	1/4"NPT	1/4"NPT	1/4"NPT
Maximum operating pressure	Planar valve	1.6 bar	1.6 bar	1.6 bar	1.6 bar
	Low-pressure valve	0.5 bar	0.5 bar	0.5 bar	0.5 bar
Maximum flow rate	9.37 GPM(36LPM)	10.8 GPM(41LPM)	12.76 GPM(48LPM)	14.6 GPM(55.7 LPM)	12.76 GPM(48 LPM)
Maximum cycles per minutes	500 cpm	550 cpm	400 cpm	450 cpm	400 cpm
Maximum volume per cycle	0.08 L	0.12 L	0.15 L	0.22 L	0.15 L
Maximum air consumption	200 L/min	250 L/min	350 L/min	400 L/min	350 L/min
Maximum size solid	Ø2 mm(0.08 in)	Ø2 mm(0.08 in)	Ø3 mm(0.12 in)	Ø3mm (0.12 in)	Ø3 mm(0.12 in)
Maximum suction lift	6.4m(252in)Wet;3.7m(146in)Dry	6.4m(252in)Wet;3.7m(146in)Dry	6.4m(252in)Wet;3.7m(146in)Dry	6.4m(252in)Wet;3.7m(146in)Dry	6.4m(252in)Wet;3.7m(146in)Dry
Net weight	R-15:3(6.1) RS-15:6(13.2)	R-18:3(6.1) RS-18:6(13.2)	R-20:4.5(9.9) RS-20:6.5(14.3)	R-23: 4.5(9.9) RS-23:6.5(14.3)	4 (8.1)
Dimensions	21x17x23 (8.27x6.7x9)	21x17x23 (8.27x6.7x9)	21x19.8x28 (9.84x7.9x9)	21x19.8x28 (9.84x7.9x9)	27x24x34 (10.6x9.5x13.4)

Aluminum-Alloy Pump Series	R-26	RS-26
Fluid inlet	(1/2 inch)	(3/4 inch)
Maximum pressure	7 bar	7 bar
Fluid inlet	1/2"NPT	3/4"NPT
Air inlet	1/4"NPT	1/4"NPT
Maximum operating pressure	Planar valve	1.6 bar
	Low-pressure valve	0.5 bar
Maximum flow rate	14.88 GPM(56 LPM)	14.88 GPM(56 LPM)
Maximum cycles per minutes	400 cpm	400 cpm
Maximum volume per cycle	0.15 L	0.15 L
Maximum air consumption	380 ml/min	380 ml/min
Maximum size solid	Ø3 mm(0.12in)	Ø3 mm(0.12in)
Maximum suction lift	6.4m(252in)Wet;3.7m(146in)Dry	6.4m(252in)Wet;3.7m(146in)Dry
Net weight	5 kg (11.1lbs)	6.5 kg (14.3lbs)
Dimensions	25x19.5x28(9.8x7.7x11)	25x19.5x28(9.8x7.7x11)



Aluminum-Alloy Pump Series	R-31/PP-31	RS-31
Fluid inlet	(1 inch)	(1 inch)
Maximum pressure	8 bar	8 bar
Fluid inlet	1"NPT	1"NPT
Air inlet	3/8"NPT	3/8"NPT
Maximum operating pressure	Planar valve	1.6 bar
	Low-pressure valve	0.7 bar
Maximum flow rate	45.19 GPM(180LPM)	45.19 GPM(180LPM)
Maximum cycles per minutes	400 cpm	400 cpm
Maximum volume per cycle	0.45 L	0.45 L
Maximum air consumption	960 ml/min	960 ml/min
Maximum size solid	Ø6 mm(0.24in)	Ø6 mm(0.24in)
Maximum suction lift	5.48m(215.7in)Wet/Dry	5.48m(215.7in)Wet/Dry
Net weight	R:9kg(19.8lbs)PP:8kg(17.6lbs)	15 kg (33.1lbs)
Dimensions	28.5x25x37.5(11.2x9.8x14.8)	28.5x25x37.5(11.2x9.8x14.8)



Aluminum-Alloy Pump Series	R-41/PP-41	RS-41
Fluid inlet	(1-1/2 inch)	(1-1/2 inch)
Maximum pressure	8 bar	8 bar
Fluid inlet	1-1/2 "NPT	1-1/2 "NPT
Air inlet	1/2 "NPT	1/2 "NPT
Maximum operating pressure	Low-pressure valve	1.3 bar
	Planar valve	1.3 bar
Maximum flow rate	79.75 GPM(300LPM)	79.75 GPM(300LPM)
Maximum air consumption	1700 ml/min	1700 ml/min
Maximum size solid	Ø8 mm(0.31in)	Ø8 mm(0.31in)
Maximum suction lift	5.48m(215.7in)Wet/Dry	5.48m(215.7in)Wet/Dry
Net weight	R:16 kg(35.3 lbs)PP:15kg(33.07lbs)	28 kg(61.7 lbs)
Dimensions	40x29x45(15.7x11.4x17.7)	40x29x45(15.7x11.4x17.7)



Aluminum-Alloy Pump Series	R-51/PP-51	RS-51
Fluid inlet	(2 inch)	(2 inch)
Maximum pressure	8 bar	8 bar
Fluid inlet	2"NPT	2"NPT
Air inlet	1/2"NPT	1/2"NPT
Maximum operating pressure	Low-pressure valve	1.3 bar
	Planar valve	1.3 bar
Maximum flow rate	154.84GPM(580LPM)	154.84GPM(580LPM)
Maximum air consumption	2700 ml/min	2700 ml/min
Maximum size solid	Ø10mm(0.39in)	Ø10mm(0.39in)
Maximum suction lift	5.48m(215.7in)Wet/Dry	5.48m(215.7in)Wet/Dry
Net weight	29.5 kg(65 lbs)PP:28.5kg(62.8lbs)	54 kg(119 lbs)
Dimensions	43x34x53(16.9x13.4x20.9)	48x39x64(18.8x15.4x25.2)





Double diaphragm

Front view of fluid regulator



BDP-12



BDP-12-S

Double diaphragm+ fluid agitator



BDP-12-B

Functions and Characteristics

- ◆ This product uses double-layer diaphragm, which is different from the products on market. Outer layer is made of special teflon, provide better solvent resistant and can be operated on as low as 15 psi.
- ◆ The maximum fluid discharge pressure is 6 bars and can not be operated without solvent. It's more durable and has longer lifetime.
- ◆ BDP series come with fluid stabiliser which can reduce sacrificing flow, suitable for transferring and mixing fluid.
- ◆ **Warning: Do not exceed the maximum pressure (0.6Mpa) when operating the pump. Prona Tools Inc will not hold any responsibility in case of accidents occur due to improper use of product.**

Type	Name	Air inlet	Fluid inlet	Usage temperature parameter	Usage air pressure Parameter	Maximum usage pressure	Fluid output per fluid cycle	Maximum cycle	Maximum flow	Demanded power of air pressure machine	Weight	Carton box size
				℃	Mpa (bar)	Mpa (bar)	ml/cycle	cycle/min	l/min	kw	kg(lbs)	LxWxH mm(in)
BDP-12	Pressure storage attached										7.3 (16.09)	
BDP-12-S	Fluid regulator and pressure storage attached	G1/4	G1/4	5-40	0.15-0.6 (1.5-6.0)	0.60 (6.0)	80	150	12	0.4-0.75	7.8 (17.20)	385X355X485 (15.16X14X19)
BDP-12-B	Agitator and pressure storage attached										11.7 (25.8)	

Air motor



M-10 M-20/30 M-40/50

Model	Power		Max. pressure	Max. rotation speed	Air consumption	Axes dimension	Weight
	HP	KW	kg/cm ² (Mpa)	rpm/min	l/min(3.5kg/cm ³)	Ømm(in)	g(lbs)
M-10	1/16	0.06	3.5(0.34)	2200	200	7(0.28)	450(1)
M-20	1/8	0.12	7(0.68)	3000	380	10(0.39)	1800(3.97)
M-30	1/4	0.19	7(0.68)	2500	360	10(0.39)	1500(3.53)
M-40	2/5	0.3	7(0.68)	2100	440	14(0.55)	4360(9.61)
M-50	1/2	0.37	7(0.68)	1420	420	14(0.55)	4360(9.61)

For more detailed air motor, please refer to page 19

Fluid regulator

RPR-5S coating passage is made of advanced stainless steel material.



RPR-5 RPR-10

Model	Pressure adjustment	Inlet connect	outlet connect	Weight	Coating passage
	kg/cm ² (Mpa)			g(lbs)	
RPR-5S	0.0-0.58(0.0-0.6)	3/8PF	1/4PF	1150(2.54)	Stainless
RPR-5	0.0-0.58(0.0-0.6)	3/8PF	1/4PF	837(1.85)	Aluminum
RPR-10	0.0-0.58(0.0-0.6)	3/8PF	1/4PF	1200(2.65)	Aluminum

Ratable fluid regulator



RPR-6S

Functions and characteristics

- ◆ Ratable regulator, can apply for adjusting fluid pressure and flow remotely. The fluid pressure and flow are adjusted by the regulator.
- ◆ The ration of air pressure and fluid output pressure can be at 1:1or 2:1or 4:1
- ◆ Coating passage is adopted advanced stainless steel material.
- ◆ The fluid pipe coupler to choose from 1/4PF or 3/8PF.
- ◆ For more stable pressure and fluid output, please use air regulator.

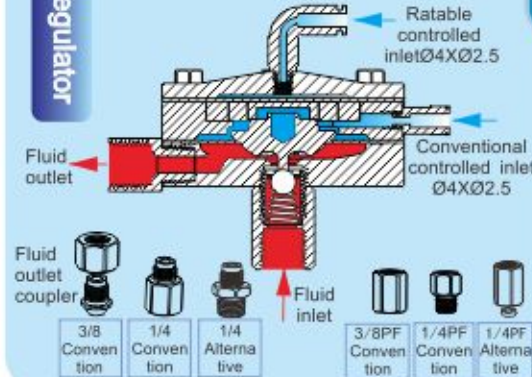

Type rag	Order number	Thread		Inlet pressure min-max bar	Outlet pressure min-max bar	Fluid flow maxi.5 bar inlet	Mano- meter bar
		Inlet	Outlet				
Pneumatic adjustment	RPR-6S-R1	Female 1/4PF	Female 1/4PF	2-15	0.5-15	1.6(Tip1.1mm)	NO
	RPR-6S-R2			1-15	0.15-7	1.3(Tip1.1mm)	NO
	RPR-6S-R4			1-15	0.15-4	0.8(Tip1.1mm)	NO
	RPR-6S-R1CO	Female 3/8PF	Female 3/8PF	2-15	0.5-15	1.6(Tip1.1mm)	NO
	RPR-6S-R2CO			1-15	0.15-7	1.3(Tip1.1mm)	NO
	RPR-6S-R4CO			1-15	0.15-4	0.8(Tip1.1mm)	NO

Air regulator



RP-101 RP-102 RP-103 RP-001

Model	Thread		Pressure gauge thread	Pressure gauge	Max pressure kg/cm ² (Mpa)	Regulation pressure range kg/cm ² (Mpa)	Functions details	Weight
	Inlet	Outlet						g(lbs)
RP-101	1/4PT(F)	1/4PT(F)	1/8PT(F)	NO (Alternative)	15(1.5)	0.7-0 (0.0-0.70)	No fill pressure type	220(0.49)
RP-102	1/4PT(F)	1/4PT(F)	1/4PT(F)				220(0.49)	
RP-103	1/4PT(F)	1/4PT(F)	1/8PT(F)				150(0.33)	
RP-001	1/8PT(F)	1/8PT(F)	1/8PT(F)				55(0.12)	
RP-001G	1/4PF(M)	1/4PF(F)	1/8PT(F)				No fill pressure type	125(0.28)
RP-002G	1/4PF(M)	1/4PF(F)	1/8PF(F)				120(0.26)	
RP-003G	1/4PF(M)	1/4PF(F)	NO	NO	55(0.12)			
RP-004G	1/4PF(M)	1/4PF(M)	1/8PF(F)	Possess	125(0.28)			

(M):Male screw, (F):Internal screw
Oper-ation way: Air, ambient temperature: 5-60 °C

Pressure gauge

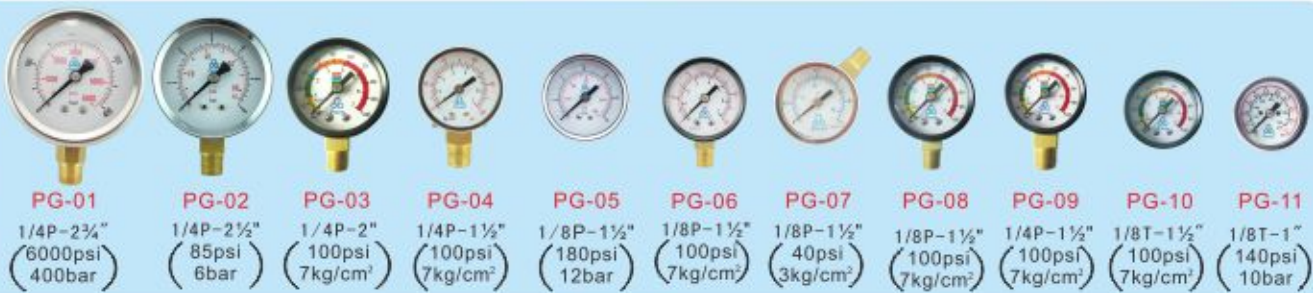

PG-01 1/4P-2 3/4" (6000psi 400bar)
 PG-02 1/4P-2 1/2" (85psi 6bar)
 PG-03 1/4P-2" (100psi 7kg/cm²)
 PG-04 1/4P-1 1/2" (100psi 7kg/cm²)
 PG-05 1/8P-1 1/2" (180psi 12bar)
 PG-06 1/8P-1 1/2" (100psi 7kg/cm²)
 PG-07 1/8P-1 1/2" (40psi 3kg/cm²)
 PG-08 1/8P-1 1/2" (100psi 7kg/cm²)
 PG-09 1/4P-1 1/2" (100psi 7kg/cm²)
 PG-10 1/8T-1 1/2" (100psi 7kg/cm²)
 PG-11 1/8T-1" (140psi 10bar)

Fluid pipe coupler



Fluid hose quick coupler



RSQ-2 1/4SM, RPQ-2 1/4PF, RSQ-3 3/8SM, RPQ-3 3/8PF

Plastic air pipe coupler



Fluid coupler

Model	Coupler 3/8-A-F-(C/S)	Coupler 3/8-A-M-(C/S)	Coupler 1/4-A-F-(C/S)	Coupler 1/4-A-M-(C/S)
Shape	F: Ordinary type	M: Spring type	F: Ordinary type	M: Spring type
A: Tube size	4X6 5X8 6.2X9.3 6.5X10 8X11 8X12 8.5X12	5X8 6.2X9.3 6.5X10 8X11 8X12 8.5X12	4X6 5X8 6.2X9.3 6.5X10 8X11 8X12 8.5X12	5X8 6.2X9.3 6.5X10 8X11 8X12 8.5X12
Material	C: Copper S: Stainless	C: Copper S: Stainless	C: Copper S: Stainless	C: Copper S: Stainless

For example: 3/8-5X8-M-C represents the coupler nut is 3/8, the size of the pipe is 5x8, and the end of the coupler with spring protection. The material is copper.

Fluid pipe coupler

Model	A	B
RFC-1P	3/8PF(F)X 3/8PF(M)	
RFC-2P	1/4PF(F)X 1/4PF(M)	
RFC-1N	3/8NPS(F)X 3/8NPS(M)	
RFC-2N	1/4NPS(F)X 1/4NPS(M)	

(M): Outer Connect (F): Inter Connect

•For more detailed of Filter, please flip to page 76.



Quick coupler



O-20PF(1/4PF) O-20PM(1/4PT) O-20MM(M12x1.0P)
 L-20PF(1/4PF) L-20PM(1/4PT) L-20MM(M12x1.0P)

Air coupler



20SF+20PF 20SH+20PH 20SM+20PM
 40SH+40PH 40SM+40PM 50SN+50PN 80SN+80PN

Fluid coupler (M): Outer Connect (F): Inter Connect

Model	A	B
1	1/4 PF(M)X 1/4 PF(M)	
2	1/4 NPS(M)X 1/4 NPS(M)	

Model	A	B
1	3/8 NPS/PF(F)X 3/8 NPS/PF(M)	
2	1/4 NPS/PF(F)X 1/4 NPS/PF(M)	
3	3/8 NPS/PF(F)X 1/4 NPS/PF(M)	
4	1/4 NPS/PF(F)X 3/8 NPS/PF(M)	

Model	A	B
1	3/8 NPS/PF(M)X 3/8 NPS/PF(M)	
2	1/4 NPS/PF(M)X 1/4 NPS/PF(M)	
3	3/8 NPS/PF(M)X 1/4 NPS/PF(M)	

*Suitable for High pressure paint

High pressure paint hose



CONSTRUCTION
 •Internal surface: Polyamide
 •Reinforcement: one or two plies of high tensile polyester textile fiber
 •Ex Rmal surface: Polyurethane
 •Application: pressure painting
 •Temperature range: -40°C~95°C

Functions and characteristics

- Safety thermoplastic hose to work at higher operating pressure.
- Excellent resistance to paints solvents and chemicals.
- Excellent flexibility, flex fatigue & non kinking.
- Superior electrical conductivity, except for KN.
- Small bend radius & very light weight.
- Excellent volumetric expansion capability

HOSE TYPE	RX1.2	RX2.3	RX2.4
NOMINAL BORE METRIC	3	4	6
HOSE ID INCH	1/8"	4/16"	1/4"
HOSE ID MILLIMETRE	3.2	4.7	6.4
HOSE OD INCH	2/7"	2/5"	1/2"
HOSE OD MILLIMETRE	7.2	10.4	12.3
MAXIMUM OPERATING in Bar	220	235	250
PRESSURE in PSI	3200	3400	3625
MINIMUM BURST in Bar	880	940	1000
PRESSURE in PSI	12800	13600	14500
MILLIMETRE	25	40	55
METER	38	73	94
COUPLER	1/4NPS	3/8NPS	

Paint hose



Inside: nylon material, solvent resisted
 Outside: PU material

Model type	Model (Standard Length 100m)
Paint hose	(Acid-proof Alkali)8*11(Light Yellow)
Paint hose	2.5*4/4*6/5*8/6*8/ 6.5*10/8*11/8*12
Reinforced plastic tubing	5*9.5/6.2*9.3/6.5*11/ 8*12/8.5*12
PE suction hose	8*10.5/9.6*12.7
PU air hose	4*6/5*8/6.5*10/8*12
PU reinforced plastic tubing	5*8/6.5*11/8*12
High-temperature paint hose	5*8 /8*11
High-pressure paint hose	6.5*12.5 /9.5*17.5
Anti-static air hose	6.5*10 /8*12
Anti-static paint hose	6.5*10 /8*11



Hose inner core of polyamide, resistant to most of the solvents used in the paint industry, cover made of polyurethane for excellent flex fatigue and abrasion resistance. Manufactured to meet special requirement and specifications, especially recommended for use with all type of air assisted and airless units. Hose can be produced without electrical conductivity.

UPON SPECIAL REQUEST

- Hose ASSEMBLIES are all fitted with bichromated steel couplings swaged permanently to the hose, stainless steel version also available(wetted parts only).
- Standard cover color blue-light, others available in large quantities at customers request.
- NON CONDUCTIVE: Specify type KNXX.

Note
 All recommendations and suggestions appearing in this bulletin concerning the use of our products are based upon test and data believed to be reliable. Since the actual use by others is beyond our control, no guarantee expressed or implied, is made by our subsidiaries, affiliates and distributors, as to the effects of such use or the results to be obtained, nor is any information to be construed as a recommendation to infringe any patent.

Fluid agitator blade



Model	Axes size	Material	Weight g(lbs)
RMB-1B	M8X1.25	Stainless	200(0.44)
RMB-2B	Ø12-M8X1.25	Stainless	232(0.51)
RMB-3B	Ø15-M8X1.25	Stainless	230(0.50)
RMB-1S	M8X1.25	Stainless	90.2(0.20)
RMB-5AS	—	Stainless	34.57(0.07)
RMB-20AS	—	Stainless	73.8(0.16)
RMB-21AS	—	Stainless	74.51(0.16)
RMB-40A	Ø12-M8X1.25	Aluminium	88.8(0.20)
RMB-CA	Ø15-M8X1.25	Aluminium	216.4(0.48)
RMB-CS	Ø15	Stainless	310(12.20)



♦ RMB-1B/1S blade is designed to reduce friction and shearing of the paint when mixing. Excellent for waterborne and high-shear paint material.

Fluid Cup

Filter CUP with 120 mesh and 200 mesh available

RFC-1 Filter Cup
1000c.c
3/8"PF

RC-1
1000c.c
3/8"PF

RCL-10B
1000c.c
3/8"PF

RC-19B
1000c.c
M16X1 (Male Screw)

RC-10A
1000c.c
M16x1.5

RC-10AP
1000c.c
M16x1.5

RCL-7B
700c.c
1/4"PF

RC-2
600c.c
1/4"PF

RC-6A
600c.c
M16x1.5

RC-6AP
600c.c
M16x1.5

RC-6M
600c.c
M16X1.5 (Male Screw)

RC-6MP
600c.c
M16X1.5 (Male Screw)

RC-6R
600c.c
M16X1.5

RC-17R
400c.c
1/4"PF

RC-4
400c.c
3/8"PF

RC-4S
400c.c
1/4"PF

RC-4R
400c.c
3/8"PF

RC-4SR
400c.c
1/4"PF

RC-5
250c.c
1/4"PF

RC-51
150c.c
1/4"PF

RC-51A
150c.c
M8X1.0

RC-51SR
150c.c
1/4"PF

RC-51M
150c.c
M8X1.0

Air Cap

R-2200AC R24 Pattern adjustable

R-2200AC R124 Pattern unadjustable

Fluid needle set Needle seal seat

R-4700AC L4700

R-4700AC H4700

NOZZLE MODEL AND SPECIFICATION COMPARISON TABLE

Tip number	Orifice mm(in)	Fluid Output		Spray angle and max fan width at gun target distance of 10"(25cm) from substrate													
		3.5Mpa 35bar 500psi	7Mpa 70bar 1000psi	10°	18°	30°	40°	45°	50°	60°	67°	75°	82°	90°			
		l/min	l/min	3.5"	5"	7"	9"	9.5"	10"	12"	13"	15"	18"	22"			
02	0.127(0.005)	0.04	0.10	106 (02-03)	206 (02-05)												
03	0.178(0.007)	0.10	0.15	107 (03-03)	207 (03-05)	307 (03-07)											
04	0.229(0.009)	0.15	0.20	109 (04-03)	209 (04-05)	309 (04-07)	409 (04-09)	04-10	509 (04-11)	609 (04-13)							
06	0.279(0.011)	0.20	0.33	111 (06-03)	211 (06-05)	311 (06-07)	411 (06-09)	06-10	511 (06-11)	611 (06-13)	06-15						
09	0.330(0.013)	0.30	0.45	113 (09-03)	213 (09-05)	313 (09-07)	413 (09-09)	09-10	513 (09-11)	613 (09-13)	09-15						
12	0.381(0.015)	0.35	0.60	115 (12-03)	215 (12-05)	315 (12-07)	415 (12-09)	12-10	515 (12-11)	615 (12-13)	12-15	715 (12-17)					
14	0.406(0.016)	0.40	0.72	116 (14-03)	216 (14-05)	316 (14-07)	416 (14-09)	14-10	516 (14-11)	616 (14-13)	14-15	716 (14-17)					
18	0.457(0.018)	0.45	0.85	118 (18-03)	218 (18-05)	318 (18-07)	418 (18-09)	18-10	518 (18-11)	618 (18-13)	18-15	718 (18-17)					
20	0.508(0.020)	0.50	1.10	120 (20-03)	220 (20-05)	320 (20-07)	420 (20-09)	20-10	520 (20-11)	620 (20-13)	20-15	720 (20-17)	820 (20-19)				
25	0.559(0.022)	0.65	1.30	125 (25-03)	225 (25-05)	325 (25-07)	425 (25-09)	25-10	525 (25-11)	625 (25-13)	25-15	725 (25-17)					
30	0.610(0.024)	0.75	1.60	130 (30-03)	230 (30-05)	330 (30-07)	430 (30-09)	30-10	530 (30-11)	630 (30-13)	30-15	730 (30-17)	824 (30-19)				
40	0.686(0.027)	0.99	2.00	140 (40-03)	240 (40-05)	340 (40-07)	440 (40-09)	40-10	540 (40-11)	640 (40-13)	40-15	740 (40-17)	827 (40-19)	927 (40-21)			
45	0.737(0.029)	1.15	2.30	145 (45-03)	245 (45-05)	345 (45-07)	445 (45-09)	45-10	545 (45-11)	645 (45-13)	45-15	745 (45-17)	829 (45-19)	929 (45-21)			
60	0.787(0.031)	1.28	2.60	160 (60-03)	260 (60-05)	360 (60-07)	460 (60-09)	60-10	560 (60-11)	660 (60-13)	60-15	760 (60-17)	831 (60-19)	931 (60-21)			

⚠ The amount of fluid output is test by water, water output data is only as reference to choose nozzle orifice , for the specific paint output ,the actual spraying shall prevail.

R-40AC R40

R-2500AC R1

R-2500AC H1

👉 Please specify the model before you buy the nozzle

Viscosity cup

Measurement method

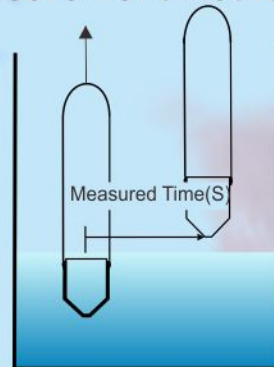

Viscosity measuring cup measures the time (second) from first drop of coating to no coating.

1Pa.s=1000mPa.s=10P
1dPa.s=0.1Pa.s=1P
1mPa.s=0.001Pa.s=1cps

Viscosity conversion table:

Type	Pa.s	dPa.s (P)	mPa.s (cps)	prona RV-2 (s sec)	prona RV-4 (s sec)	Ford(S sec) #4 #3	Zahn(S sec) #4 #2	Krebs KU (S sec)
Low Viscosity	0.01	0.1	10			5	16	
	0.015	0.15	15			8	17	
	0.02	0.2	20	5	12	10	18	
	0.025	0.25	25	8	15	12	19	
	0.03	0.3	30	11	19	15	20	
	0.04	0.4	40	14	25	17	22	
	0.05	0.5	50	16	29	19	24	
	0.06	0.6	60	19	33	21	27	
	0.07	0.7	70	21	36	23	30	
	0.08	0.8	80	25	41	26	34	
0.09	0.9	90	29	45	29	37		
0.10	1.0	100	31	50	31	41	10	
0.12	1.2	120	38	58	36	49	11	
0.14	1.4	140	44	66	41	53	13	
0.16	1.6	160	49	67	45	56	14	
0.18	1.8	180	56		51	64	16	
0.20	2.0	200	63		56	74	17	
0.22	2.2	220	69		61	82	18	
0.24	2.4	240	76		67	91	20	
0.26	2.6	260	83		72	100	21	
0.28	2.8	280	88		76	110	22	
0.30	3.0	300	96		83	120	24	
0.40	4.0	400				150	30	
0.50	5.0	500				180	37	
0.60	6.0	600				210	44	
0.70	7.0	700				240	51	
0.80	8.0	800				270	58	
0.90	9.0	900				300	64	
1	10	1000				330	71	
2	20	2000				360	74	
3	30	3000				390	77	
4	40	4000				420	81	
						450	85	
						480	103	
						510	121	
						540	133	

Tip filter

Model	RF-60	RF-80	RF-100	RF-150	RF-200
Color	White	Green	Black	Red	Yellow
Mesh	60	80	100	150	200

Cleaning set



Double diaphragm+cart



Model of double diaphragm

R-15	RS-15
R-18	RS-18
R-20	RS-20
R-26	RS-26



Water-based paint blower



Functions and characteristics

- ◆ Designed for accelerating the drying of waterborne paint, provide high volume air flow, speed up drying time
- ◆ Filter that made of stainless steel can reduce the risks of imperfection in the paintwork.
- ◆ Suitable for drying large surface such as vehicle; or small area like phone parts.
- ◆ **Warning: the direction of blowing must be the same as the wind direction in the operation room to increase stability of air flow .**

Model	Name	Working pressure	Maximum pressure	Air consumption	Maximum air flow	The maximum amount of wind	Dry distance	Weight
		bar(PSI)	bar(PSI)	L/min	L/min	L/min		
RP-1	Small flow	2.9 (43)	6.8(98)	270	10:1	2700	300-800(11.8-31.49)	265(0.58)
RP-2	Large flow	2.9 (43)	6.8(98)	700	4:1	2800	300-800(11.8-31.49)	633(1.40)



R-SP1021
Mini Model

R-SP1628
R-SP1636
Light Model

R-SP2544
R-SP2554
R-SP2578
Super Model

Functions and characteristics

- ◆ Improved paint passage can efficiently reduce the usage of cleaning solvent and the amount of waste paint that generated during the cleaning process by 30%. (When compared with conventional model.)
- ◆ Has the advantage of easy cleaning, lower cost and reduce maintenance time.
- ◆ Special ring springs are used for gland packing, eliminating the need of tightening packing.
- ◆ Suitable for zinc-rich paint during large-scale construction.

Name	Mini model	Light model	Light model	Super model	Super model	Super model
Model	R-SP1021	R-SP1628	R-SP1636	R-SP2544	R-SP2554	R-SP2578
Pressure ratio	1:23	1:30	1:20	1:65	1:45	1:20
Max. paint pressure	11.5Mpa	15Mpa	10Mpa	32.5Mpa	22.5Mpa	10Mpa
Max. air pressure	0.5Mpa	0.5Mpa	0.5Mpa	0.5Mpa	0.5Mpa	0.5Mpa
Normal of discharge	1.3L/min	2.2L/min	3.2L/min	4L/min	6L/min	8L/min
Max. rate of discharge	4L/min	6.8L/min	10L/min	14L/min	20L/min	30L/min
Air hatch	G1/4			RC 3/4		
Fluid outlet	G3/8					
Compressor	0.75kw(1PS)	1.5kw(2PS)	1.5kw(2PS)	5.6kw(7.5PS)	5.6kw(7.5PS)	5.6kw(7.5PS)
Size WxDxH mm in	320X400X750 (12.6X15.7X29.5)	350X500X900 (13.8X19.7X35.4)	350X500X900 (13.8X19.7X35.4)	600X720X1280 (23.6X28.3X50.4)	600X720X1280 (23.6X28.3X50.4)	600X720X1280 (23.6X28.3X50.4)
Weight(kg/ lbs)	14(30.9)	32(70.5)	33(72.8)	105(231.5)	110(242.5)	115(203.5)

Dry blower stand

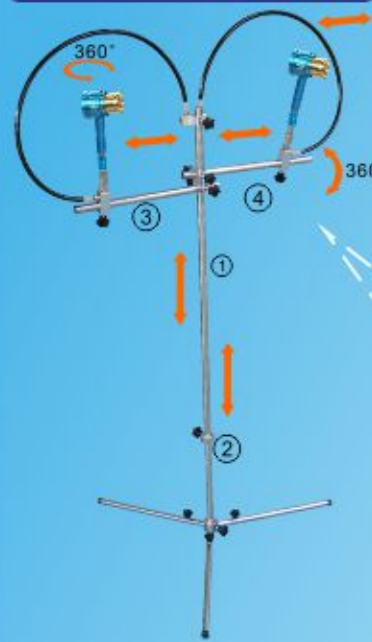

RPS-1

Functions and characteristics

- ◆ Blow guns can be used with stand in paint room or coating place.
- ◆ The drying time can be accelerated by adjusting the angle and blowing distance.
- ◆ The stand is made of light material and supported by firm triangular framework.
- ◆ Both height and width of stand are adjustable.
- ◆ The position of blow gun can be adjusted 360 degree.

Technical parameters

- The maximum adjustable height of the bracket is about 200cm.
- Pole ① can be extended about 100cm long.
- Pole ② can be extended about 90 cm long.
- Total adjustable width is about 80cm.
- Adjustable width of the pole ③ and ④ are about 40 cm.

Caution

Ensure each screws have been tightened before use.
To avoid danger, the bracket can not be moved while being used.
After use, turn off the air, lower down the bracket to safety height.

Telescopic type magnetic suction blower gun support

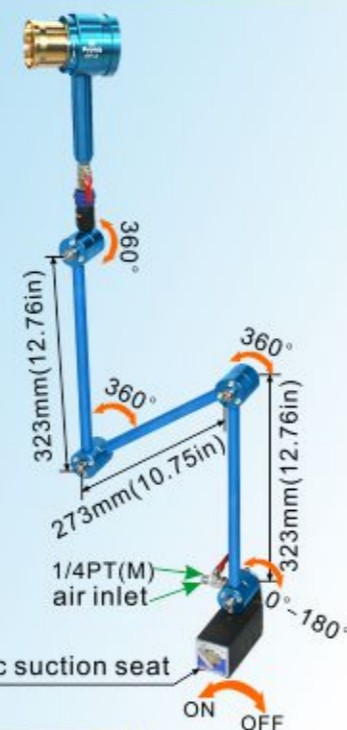

RPS-2